

Seats

Component Location

NOTE :

RH drive shown, LH drive similar

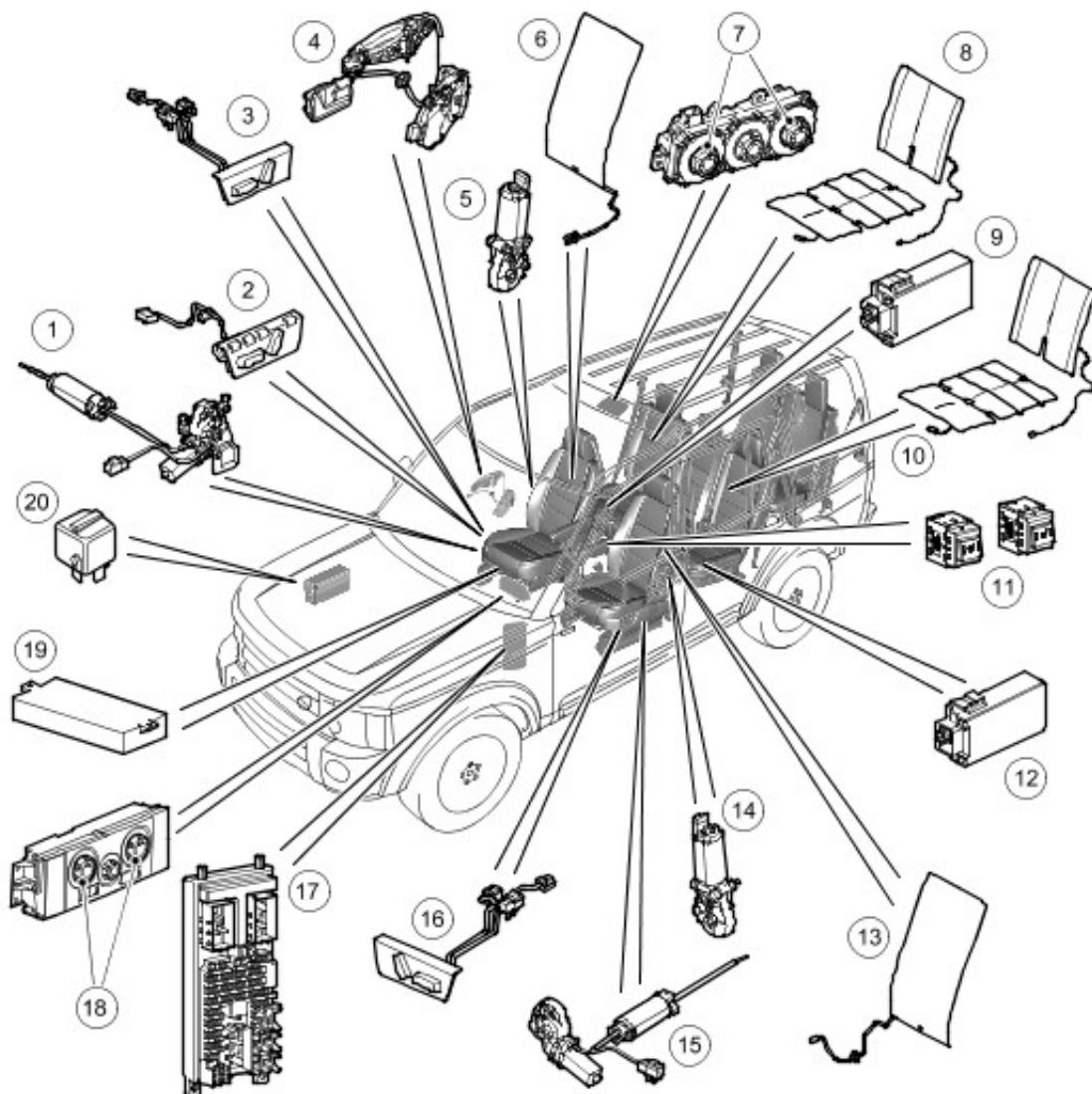

E48947

Item	Part Number	Description
1	-	Drivers seat cushion adjustment motor assembly
2	-	Drivers seat memory switch pack
3	-	Drivers seat non-memory switch pack
4	-	Drivers door ajar switch
5	-	Drivers seat squab motor
6	-	Drivers seat heating element
7	-	Second row heated seat switch pack (vehicles with rear air conditioning)
8	-	Second row RH seat heating element
9	-	Second row RH seat heating module
10	-	Second row LH seat heating element
11	-	Second row heated seat switches (vehicles without rear air conditioning)
12	-	Second row LH seat heating module

13	-	Front passenger seat heating element
14	-	Front passenger seat squab motor
15	-	Front passenger seat cushion adjustment motor assembly
16	-	Front passenger seat switch pack
17	-	Central Junction Box (CJB)
18	-	Front heated seat switch pack (climate control system)
19	-	Memory control module
20	-	Front passenger seat power relay

OVERVIEW

Seat Configuration

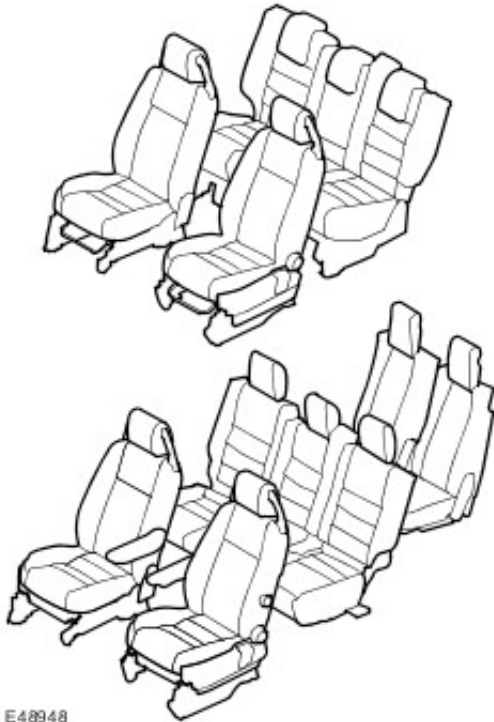

E48948

Discovery 3 is available in a 5 or 7 seat configuration. The driver's seat has the option of an 8-way power adjustment, with or without memory functionality, or a 6-way manual adjustment. The front passenger seat has the option of a 6 way power adjustment or a 4-way, non-height, manual adjustment. On vehicles from 2008MY, the front passenger seat can be fitted with an 8-way power adjustment.

The type of second row seats depends upon whether the 7-seat option is fitted. If the vehicle supports 5 seats, the 2nd row is designed as a 60/40 split, flip and fold configuration, whereas a vehicle that supports the 7 seat option is designed as a 35/30/35 split with the 2 outer seats having the ability to 'jack-knife', allowing access to the 3rd row of seats.

All seats are available in a fabric, duragrain or leather finish depending on model specification.

MANUAL FRONT SEATS

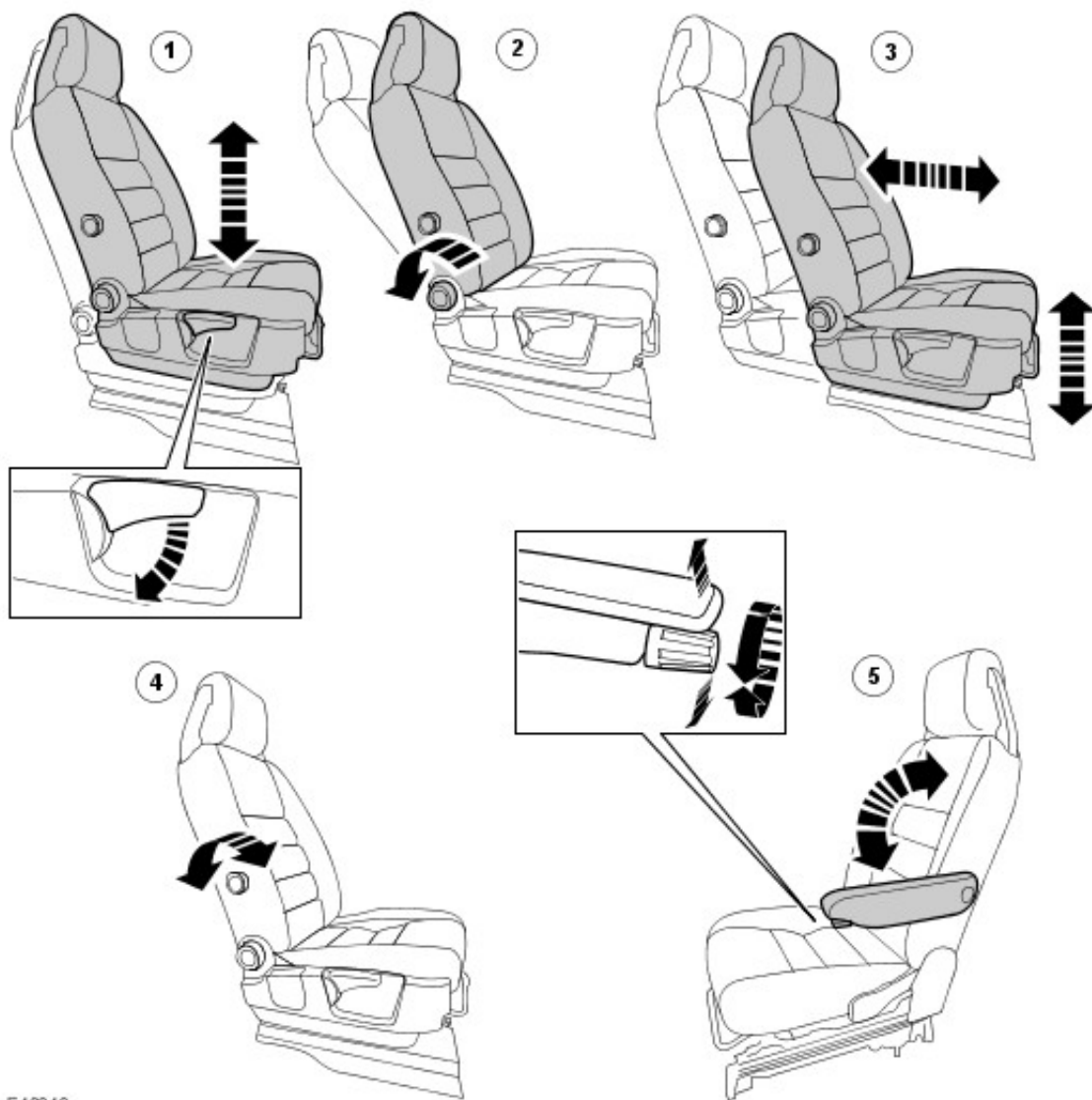

E48949

Item	Part Number	Description
1	-	Height adjustment (drivers seat only)
2	-	Recline adjustment
3	-	Forward/backward adjustment
4	-	Lumbar support adjustment
5	-	Folding armrest adjustment (if fitted)

Height adjustment (drivers seat only)

Pumping the handle controls seat height. Pumping the lever upwards raises the seat; downwards lowers the seat.

Recline adjustment

The angle of the backrest is adjusted by turning the rotary wheel either clockwise or anticlockwise.

Forward/backward adjustment

Lifting the tomel bar at the front of the seat and sliding the seat to the desired position achieves the forwards/backwards adjustment.

Lumbar support adjustment

A hand wheel in the side of the seat provides for adjustment of lumbar support.

Folding armrest adjustment (if fitted)

Some vehicles are fitted with adjustable front seat armrests. These are used in the horizontal position or can be stowed vertically alongside the seat back rest. The horizontal position can be adjusted for height by turning the knob set into the end of the armrest.

POWER OPERATED FRONT SEATS (NON-MEMORY)

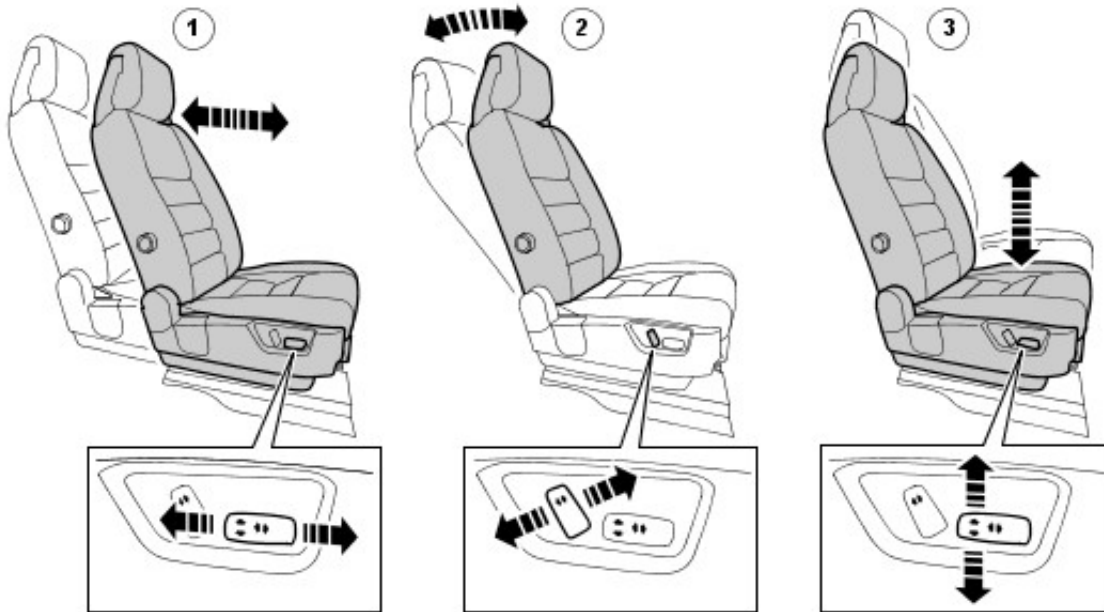

E488950

Item	Part Number	Description
1	-	Forward/Backward adjustment
2	-	Seat back adjustment
3	-	Seat cushion height adjustment

Forward/Backward adjustment

Push and hold the switch forwards or backwards to move the seat to the desired position.

Seat back adjustment

Twist the switch forwards or backwards until the desired seat back angle is achieved.

Seat cushion height adjustment

Push the switch up or down to raise or lower the cushion.

Front Seat Motors

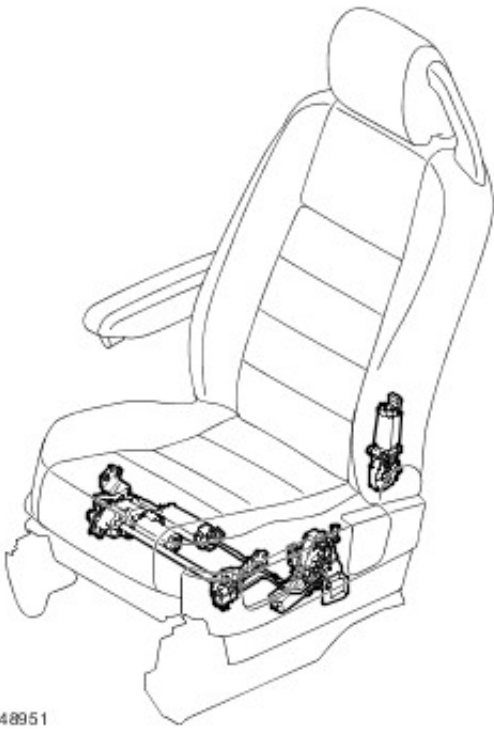

E48951

NOTE :

On vehicles from 2008MY, the passenger seat can also be fitted with 8-way electrical adjustment.

The seat motors are a permanent magnet motor type coupled to a rack and pinion assembly. Should the motor seize or stick an internal thermal cut-out switch will trip to remove voltage from the motor. Two pins within each of the seat switch packs control the seat motors. Both pins are normally earthed. Operating the switch applies voltage to one of the pins while the other pin remains earthed. Operating the switch in the opposite direction reverses power and earth to the motor allowing the motor to run in the opposite direction.

Lumbar Adjustment - Vehicles From 2008MY

On vehicles from 2008MY the electric front seats are fitted with electric lumbar adjustment. The lumbar pump inflates a bladder in the backrest which provides extra support for the seat occupant.

Lumbar Adjustment Switch Location

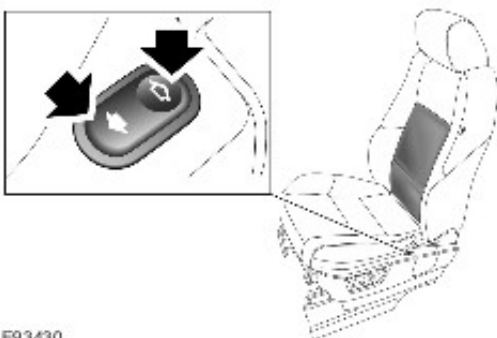

E93430

Adjustment is achieved by operation of a rocker switch located on the outside of the seat, on the upper face of the side cushion trim. The switch is connected to an air pump, which inflates a lumbar bladder to provide the required lumbar adjustment. The air pump will operate for as long as the switch is operated in the inflate position. When the switch is operated in the deflate position, the switch operates a deflate solenoid to allow the air to escape from the bladder. The lumbar bladder is protected from over inflation by a pressure relief valve.

DRIVERS MEMORY SEAT

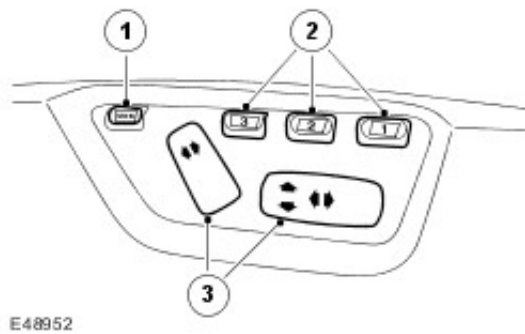

E48952

Item	Part Number	Description
1	-	Memory store button
2	-	Memory preset buttons
3	-	Seat adjustment controls

The memory control module can store up to three different driver seating, mirror and electric steering column (where fitted) positions for each key (up to 3 keys). The three-numbered memory and single memory store switches control memory storage and recall operations. Each switch is a momentary action push switch.

All seat adjustments are available whilst the ignition key is in position I or II or for a time period from when either the driver door status is changed or the ignition key status changes from position I to position 0 (key in).

NOTE :

This does not include lazy entry where the door is not required to be open, or the ignition key is in position I or II.

The mirror adjustment is only enabled when the ignition key is in position I or II.

Memory Recall

Memory recall has three memory positions stored for the seats, exterior mirrors and electric steering column (where fitted). The switches for this function are located on driver's seat outer side trim panel. Pressing the appropriate numbered memory switch allows the seat to start moving to the position appropriate to that memory.

When a memory recall is initiated, to limit the overall current consumption, only two-seat axis will move towards their intended position at any one time. To minimise current load as the motors start, the initiation of each axis is phased with a 10ms delay between each motor starting.

The cushion slide and backrest will move first, followed by the cushion height and tilt. If the vehicle is stationary, the memory recall will operate in a 'one-touch' mode, whereby the switch can be released and the seat will continue to move to the memory position. If, however, the vehicle is in motion when the switch is released, then the system will operate in manual mode. This means that when the switch is released, the seat will stop moving. In order to reach the intended memory position, the switch must not be released until all movement has stopped. The instrument cluster will emit a double chime to indicate that the recall operation has been successfully completed.

The following procedure will store a memory position:

- Ensure the ignition key is in position I or II
- Ensure reverse gear is not engaged
- Manually adjust the seat to the desired position, using the seat switches
- Press and release the 'memory store' switch
- Press and release the desired numbered memory switch within 5 seconds

With the ignition key in position II, a single chime will be emitted from the instrument cluster to indicate that the store operation has been successful.

If any of the seat adjustment or memory switches are activated during a 'one touch' memory recall, the recall will be overridden and the seat will begin to move in the direction corresponding to the switch that has been pressed.

Both mirrors move simultaneously about the vertical axis first (left/right), and then, once all vertical axis movements are complete, about the horizontal axis (up/down). To minimise the number of mirror motor's required, a method of sharing is implemented, which dictates that all movement about one axis is complete before movement about the other axis commences.

Mirror movement coincides with the following table:

Action	Control Module Pin 14	Control Module Pin 7	Control Module Pin 13	Control Module Pin 8
Driver Mirror Up	Battery	-	-	-
Driver Mirror Down	Ground	-	-	-
Driver Mirror Left	-	Ground	-	-
Driver Mirror Right	-	Battery	-	-
Passenger Mirror Up	-	-	Battery	-
Passenger Mirror Down	-	-	Ground	-
Passenger Mirror Left	-	-	-	Ground
Passenger Mirror Right	-	-	-	Battery

Lazy Entry

Pressing the unlock button on the remote transmitter will initiate a memory recall. This feature is known as 'lazy entry'. If the seat movement, memory switch or the lock button on the remote transmitter is pressed, then the 'lazy entry' feature will stop immediately.

The memory settings are stored within Electronic Erasable Programmable Read Only Memory (EEPROM) of the memory control module each time the ignition switch is cycled from position II to position I. These are the positional values that a lazy entry request uses when the remote unlock button for that particular key is next pressed.

The lazy entry feature can be activated or deactivated via the customer personalisation feature of the high line instrument cluster. This provides the driver with the option to enable or disable lazy entry as required. For additional information, refer to Information and Message Center (413-08 Information and Message Center)

Immediate Adjustment

Pressing one of the manual adjustment switches will initiate the corresponding motor for that axis until the switch is released.

Only two seat motors can be driven at any one time. However, due to the sharing of relays, there are certain combinations of motors that cannot be driven together. The following table indicates which axis can and cannot be operated at the same time:

	Recline Up	Recline Down	Tilt Up	Tilt Down	Height Up	Height Down	Slide Forward	Slide Backward
Recline Up	-	No	Yes	Yes	Yes	Yes	Yes	Yes
Recline Down	No	-	Yes	Yes	Yes	Yes	Yes	Yes
Tilt Up	Yes	Yes	-	No	Yes	Yes	No*	No*
Tilt Down	Yes	Yes	No	-	Yes	Yes	No*	No*
Height Up	Yes	Yes	Yes	Yes	-	No	No*	No*
Height Down	Yes	Yes	Yes	Yes	No	-	No*	No*
Slide Forward	Yes	Yes	No*	No*	No*	No*	-	No
Slide Backward	Yes	Yes	No*	No*	No*	No*	No	-

Key

- - = Not applicable
- Yes = Can be activated together
- No = Can not be activated together (Physically impossible)
- No* = Can not be activated together (Relay sharing restriction)

If two axis are being driven and a third axis is requested to move, the third switch request is ignored until either of the two

axis switches, already active, are released. The third axis movement may only be initiated providing the switch has been released and re-selected.

Seat adjustment can be initiated simultaneously with any mirror movement.

REVERSE GEAR MIRROR POSITION

To give the driver a clear view of the kerbs when reversing, the exterior door mirror's can be dipped when reverse gear is selected. The level of mirror dipping is set to a predetermined amount when the vehicle leaves the factory but has the ability to be customer programmed.

The following procedure will store a reverse gear mirror position:

- Ensure the ignition key is in position I or II
- Perform a memory recall procedure
- Ensure reverse gear is engaged
- Manually adjust the mirrors to the desired position
- Press and release the 'memory store' switch
- Press and release the desired numbered memory switch
- Reverse gear mirror dip setting will be stored for that particular memory setting.

A single chime will be emitted from the instrument cluster to indicate that the store operation has been successful and 'Mirror Dip Stored' message will be displayed in the message centre.

Once this sequence has been completed, the stored mirror position will be the position that the mirrors move to when reverse gear is next selected.

Storing a memory position with reverse gear selected only affects reverse gear mirror positions, the remainder of the memory position's remain unchanged.

To protect against an accidental setting, the mirror position will only be stored if a mirror adjustment has been made since reverse gear was selected. If there is no reverse gear mirror position stored, then a default setting, stored in the memory control module, is adopted.

There are three customer personalisation memory settings per key. For each of these settings there are 3 possible reverse gear mirror position stores. This equates to a possible nine reverse gear mirror position settings. Personalisation memory setting relates to the 3 most recent ignition keys.

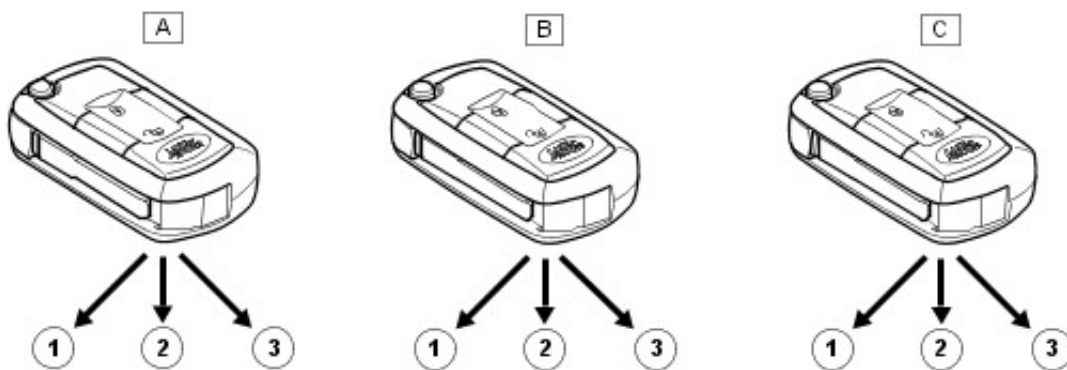

E48953

Item	Part Number	Description
A	-	Most recent ignition key
B	-	Second most recent ignition key
C	-	Third most recent ignition key
1	-	First reverse gear mirror position store
2	-	Second reverse gear mirror position store
3	-	Third reverse gear mirror position store

The reverse gear mirror position feature can be activated or deactivated via the customer personalisation feature of the high line instrument cluster. This provides the driver with the option to enable or disable reverse gear mirror position as required. For additional information, refer to Information and Message Center (413-08 Information and Message Center) Information regarding the reverse gear mirror status, for both manual and automatic transmissions, is transmitted as a message on the Local Interconnect Network (LIN) bus.

When the reverse gear mirror position feature is toggled 'OFF', all 3 memory settings associated with that personalisation memory will return to the default reverse gear mirror settings.

NOTE :

Reverse gear status is only available with the ignition in position II.

When reverse gear is de-selected, the mirror position immediately prior to reverse selection will be resumed, unless a memory recall has been requested whilst reverse has been selected, in which case the mirrors will move to the requested memory position when reverse is de-selected.

On vehicles fitted with the ZF automatic transmission there is a delay of 0.5 second following the selection of reverse gear, prior to the reverse mirror position being recalled. This is to prevent any movement of the mirrors as the gear selector is moved through the reverse position on the way to, and from, the park position.

STEERING COLUMN ADJUST (where fitted)

The memory control module controls the electric adjustable steering column in a rake (up and down) and reach (in and out). The steering column can be adjusted for rake and reach by operating the rotary joystick control switch on the LH side of the steering column.

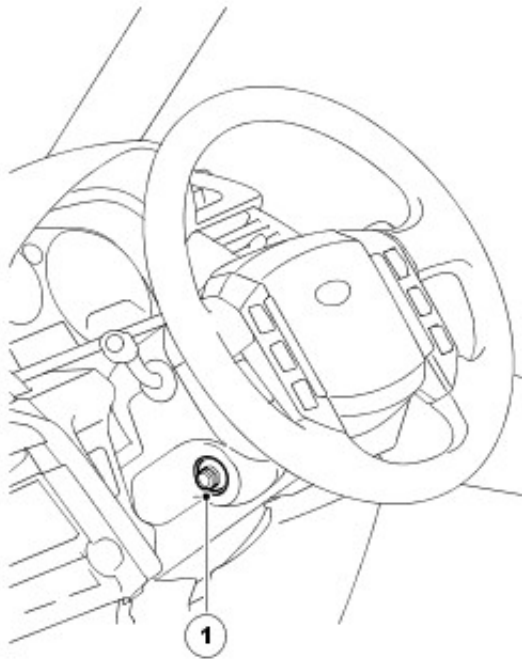

E57136

Item	Part Number	Description
1		Rotary joystick control switch

To adjust the steering column:

- Turn the switch to the 'Column' or 'Auto' position
- Move the switch forwards or backwards to adjust the reach
- Move the switch up or down to adjust the rake.

Entry/Exit Mode

Entry/Exit mode provides automatic movement of the steering column and driver's seat to allow easier entry to or exit from the vehicle.

Entry/Exit mode is selected by setting the steering column adjustment switch to the 'AUTO' position.

NOTE :

If the adjustment switch is moved away from 'AUTO' whilst the steering column is tilted away, the steering column will move back to it's memorised position when the key is next inserted in the ignition. Entry/Exit mode will then be cancelled.

NOTE :

If the adjustment switch is moved during entry/exit operation, steering column movement will stop.

Exit

When the ignition key is removed, the steering column will move to the uppermost rake and innermost reach positions and the driver's seat will move slightly rearwards and lower.

Entry

When the key is inserted in the ignition the steering column and seat will return to their previous positions. If, however, the memorised driver position has been changed (using the seat memory switches or another key transmitter), the steering wheel and seat will move to the new position.

Steering Column Control

Adjustment of the steering column is achieved by a single DC motor. Each adjustment movement is transmitted through a solenoid actuated clutch; one clutch for reach movement and one for rake movement.

When engaged, a clutch can be released only if the system is unstressed. As the clutches are mounted on the same motor spindle, the sequence for position adjustment is as follows:

- Engage the selected clutch by powering the appropriate solenoid
- After a time period (approximately 0.1 of a second), the motor is powered in the desired direction
- When the motor reaches the stop position the solenoid and motor is released/unpowered. The clutch remains engaged under stress
- After a time period (approximately 0.1 of a second), the motor is powered in the opposite direction to enable the clutch to disengage when the stress is released.

Motor Rotation Direction	Clockwise	Counter Clockwise
Reach movement	IN	OUT
Rake movement	UP	DOWN

Simultaneous rake and reach movements are not possible since the motor must reverse direction as soon as the first axis has reached it's required position.

Steering column rake and reach is controlled via potentiometer feedback.

AUDIBLE AND VISUAL CONFIRMATIONS

An audible confirmation is generated by the instrument cluster to provide confirmation to the driver that the requested operation has been successfully completed. The following operations support an audible confirmation:

Operation	Audible Confirmation	Conditions
Memory Store	Single Chime	Successful store operation completed
Memory Recall	Double Chime	Only issued if all axis of movement successfully reach the intended position
Reverse Gear Mirror Position Store	Single Chime	Successful store operation for reverse mirror position completed

In addition to audible confirmation there is also a visual confirmation via the instrument cluster message centre. For additional information, refer to Information and Message Center (413-08 Information and Message Center)

MEMORY CONTROL MODULE



E48954

Item	Part Number	Description
1	-	Memory control module

The memory control module, located under the driver's seat, relies upon a number of inputs and controls a number of outputs. As with all electronic control modules, the unit needs information regarding the current operating conditions of the engine and other related systems before it can make calculations, which determine the appropriate outputs.

All memory values are stored in the non-volatile memory, EEPROM. The current motor positions, which are monitored by the control modules integral Hall sensors, are stored in the EEPROM. If a loss of power occurs, upon power reconnection the current motor position are recalled from memory and adopted as the current positions. This will allow the relative memory positions to be retained without any need to re-calibrate. The memory control module checks the integrity of all data stored in the EEPROM each time it exit's stand-by mode. In the event that the data is corrupt, the control module adopts the default values for all of the programming options. All memory positions are deemed as invalid and the software will perform as if there are no memory positions stored. Memory store operations will reset the relevant memory and allow full functionality.

Stall Detection

Seat, steering column (where fitted) and mirror motors are deemed to have stalled if there is no change in the inputs that are received from the corresponding feedback sensors for 200ms (seat), 1000ms (mirror & steering column) while that axis is being driven.

If a stall condition is detected then the drive to that axis is cancelled for the remainder of that memory operation (memory recall) or until the switch is re-selected (manual movement).

If the motor movement has stopped due to loss of sensor feedback, either stall or sensor failure, then that axis may be activated again, to move past the stall position, by re-selecting the appropriate switch. This allows control of the motor to be maintained if sensor feedback is lost.

Upon re-selection of movement, if sensor pulses are detected then the motor will continue to be driven until the switch is released or another stall condition is detected. If sensor feedback is not detected then the motor is only driven for 0.5 second and then stops until the switch is released and then pressed again, when a further 0.5 second of activation is permitted, and so on.

For all seat motor and steering column manual movements, whenever a motor is driven and a stall occurs, the memory control module records the position at which the stall occurred. If movement occurs beyond a stall position, then that position is erased from the control modules memory. This will always allow movement past a previously recorded stall position once movement has been registered beyond that position. This is the case for both manual and memory movement.

Initialisation

When a replacement memory control module is fitted to a seat it should be initialised so that the control module can learn the seats and steering column maximum and minimum adjustment values. This is achieved by:

- adjusting all seat movement axis from one end of travel to the other; slide, recline, height and tilt
- adjusting all steering column movement from one end of travel to the other; rake and reach.

Battery Monitor

If the battery voltage drops below 10.5 Volts, then the memory control module ignores all requests for a memory recall, including lazy entry, or easy entry/exit until the battery voltage has reached 11.5 Volts. This will conserve as much power in the vehicle battery as possible to enable engine cranking.

Stand-by Mode

The memory control module supports a stand-by mode to keep power consumption to a minimum.

The control module will enter stand-by mode upon receipt of a LIN bus 'SLEEP' message from the Central Junction Box (CJB). Alternatively, a time period of 3 seconds after the LIN bus network has remained quiet provided there are no motors being driven at that time and there are no valid switch requests.

If there is a failure with the LIN bus network then the seat will be operational in 'inch mode' only.

If the control module is being prevented from entering stand-by mode due to motor movement, memory recall or switch operation, then it will enter stand-by mode when the current function has terminated.

NOTE :

In the case of a memory recall, all memory recall operations should be carried out before entering stand-by mode, not just the current motor movement.

The control module will exit stand-by mode if there is any LIN bus activity. When the control module exits stand-by mode it must verify the 'System Enable Status' in order to recognise when it should respond to a switch request.

SEAT HEATING

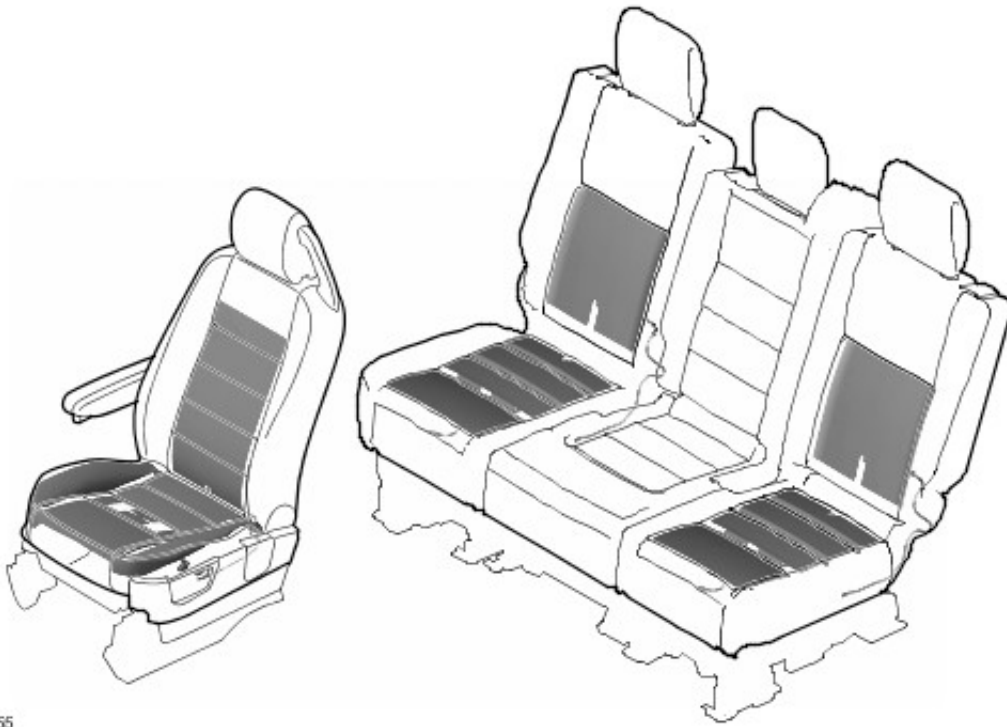

E48955

Front Seats

Front Seat Heater Switches

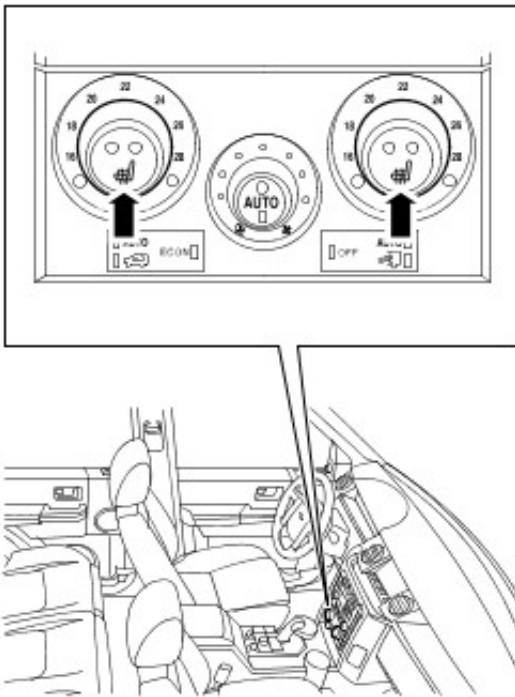

E48956

The heated front seat system is available on both manual and electric seats and is controlled by the Automatic Temperature Control Module (ATCM).

When the front seat heater switch is operated, power is supplied to the heater elements in the seat, causing the seat to heat up. The ATCM senses seat temperature via the sensor in the cushion and regulates voltage to the seat heater elements to maintain a constant temperature. For additional information, refer to Control Components (412-04 Control Components)

Rear Seat Heaters

Rear Seat Heater Switches

NOTE :

Rear air conditioning variant shown

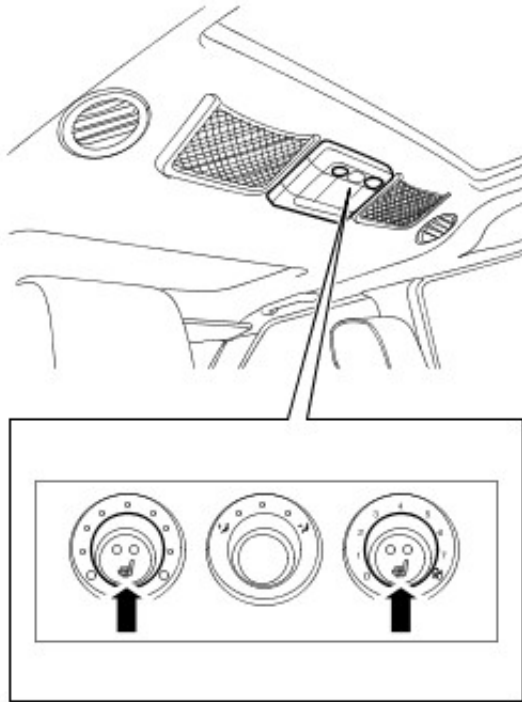

E48957

The RH and LH rear seats support three integral heating elements, squab, back rest and bolster. The optional rear child booster seat also supports an integral seat-heating element.

NOTE :

The rear centre seat is not available with seat heating.

The rear seat heaters are enabled when the ignition switch is position II, and operate at one of two temperature settings. With the first press of a rear seat heater switch the relative rear seat heat control module (RH or LH) adopts the higher temperature setting, supplies a power feed to the related rear seat heater elements and illuminates two amber LED's in the switch. At the second press of the switch the control module adopts the lower temperature setting and extinguishes one of the LED's. At the third press of the switch the control module de-energises the heater elements and extinguishes the second LED. The seat heaters remain on until selected off or the ignition is turned off.

The rear seat heat control modules receive an input from a temperature sensor in RH and LH rear seats, and regulate the power feed of the heater elements to control the seat temperature at the appropriate temperature setting between 35 and 45 °C (95 and 113 °F). The actual temperature settings vary with the type of seat covering, to allow for the different heat conduction properties of the different seat covering materials.

DIAGNOSTICS

The exchange of information between the diagnostic unit and the memory control module is via the CJB, which are interconnected via the hi-speed Controller Area Network (CAN) bus and LIN bus. There is a non-volatile memory (EEPROM) for saving detected errors. Its contents are not lost when the power supply is disconnected. Only a Land Rover approved diagnostic system can erase the error memory.

CONTROL DIAGRAM

NOTE :

A = Hardwired; J = CAN bus

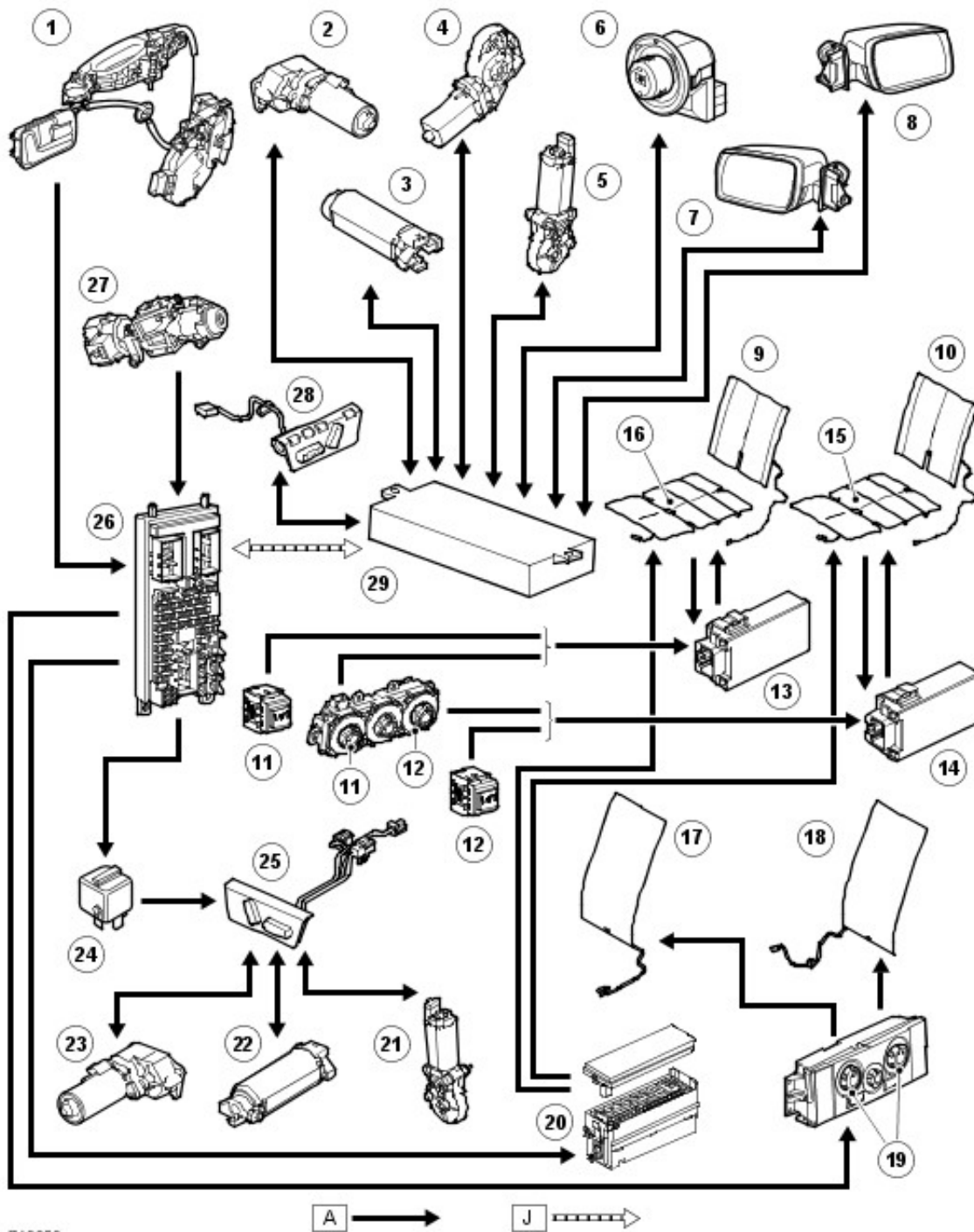

E48958

A → J →

Item	Part Number	Description
1	-	Drivers door ajar switch
2	-	Drivers seat height motor
3	-	Drivers seat slide motor
4	-	Drivers seat tilt motor
5	-	Drivers seat recline motor
6	-	Mirror adjustment switch
7	-	LH mirror motor
8	-	RH mirror motor
9	-	LH rear seat heater
10	-	RH rear seat heater
11	-	LH rear seat heater switch
12	-	RH rear seat heater switch
13	-	LH rear seat heater control module

14	-	RH rear seat heater control module
15	-	RH rear seat heater cut-off switch
16	-	LH rear seat heater cut-off switch
17	-	Drivers seat heater
18	-	Front passenger seat heater
19	-	Front seat heater switches
20	-	Battery Junction Box (BJB)
21	-	Front passenger seat recline motor
22	-	Front passenger seat slide motor
23	-	Front passenger seat height motor
24	-	Front passenger seat power relay
25	-	Front passenger seat switch pack
26	-	Central Junction Box (CJB)
27	-	Ignition switch
28	-	Drivers seat switch pack
29	-	Memory control module