

Concern Identification and Associated Repair Procedure:

X-TYPE - Model Range

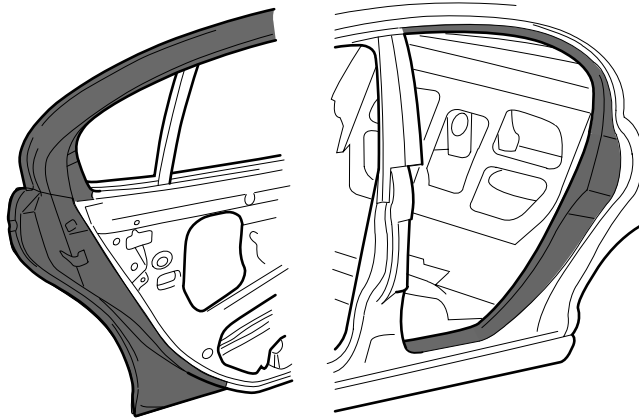
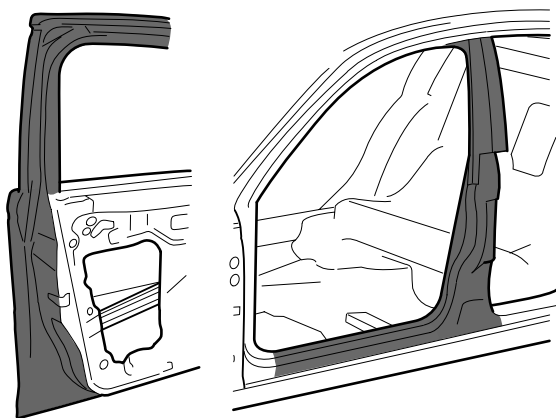
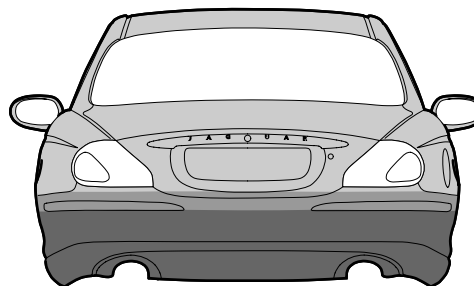
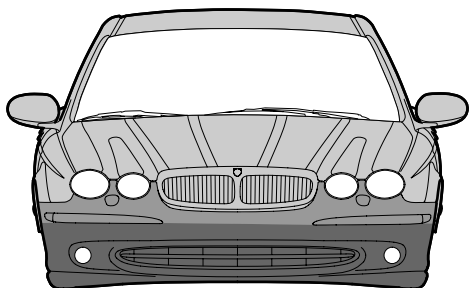
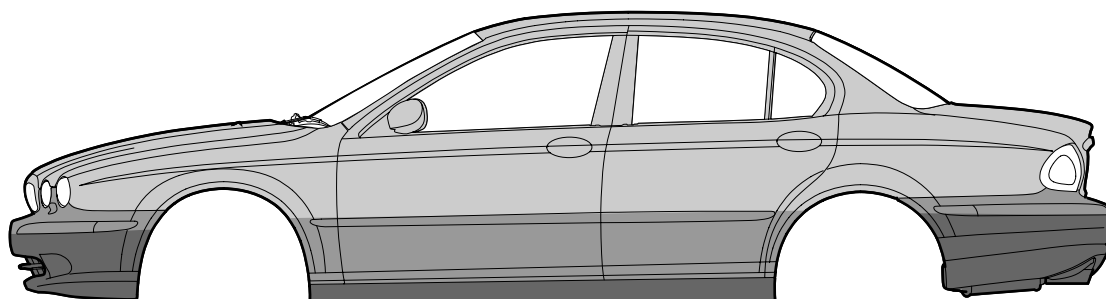
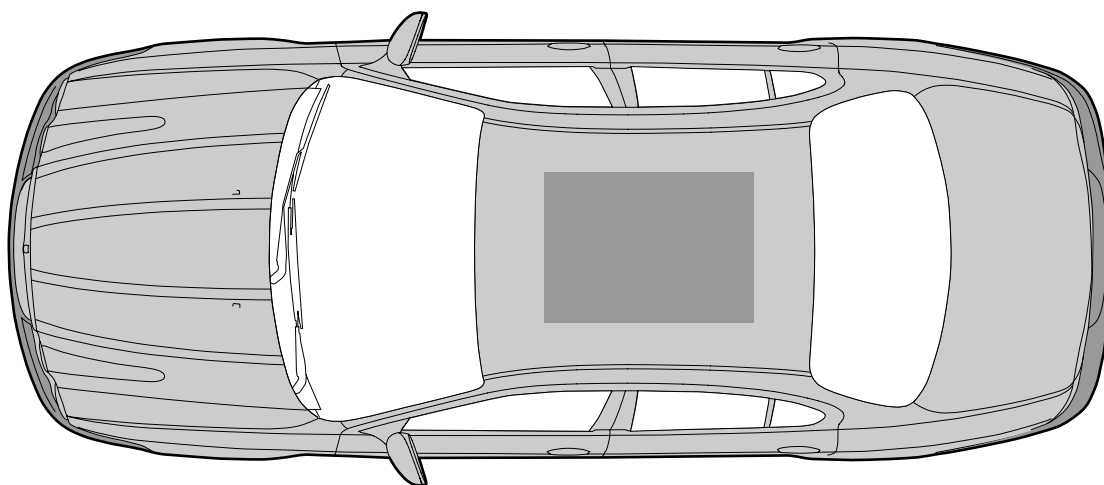

The shaded areas on the diagrams relate to the following zones:

'A' ZONE

High visibility

'B' ZONE

Medium to Low visibility

'C' ZONE

Low to hidden visibility

501.2683

X-TYPE ESTATE- Model Range

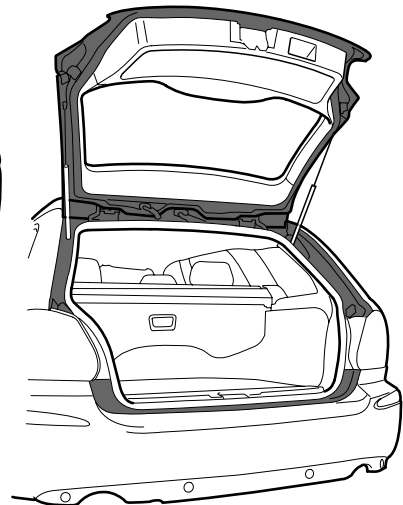
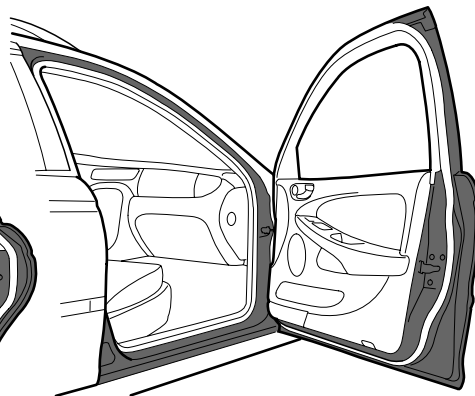
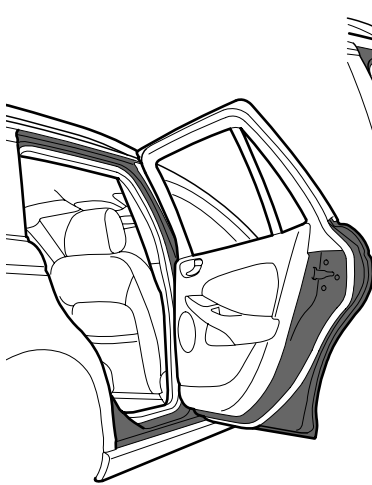
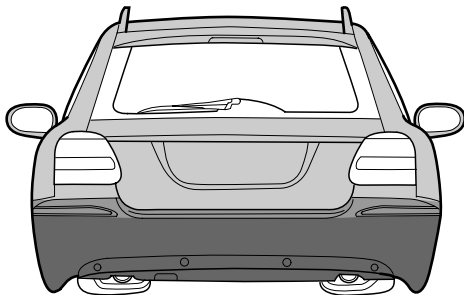
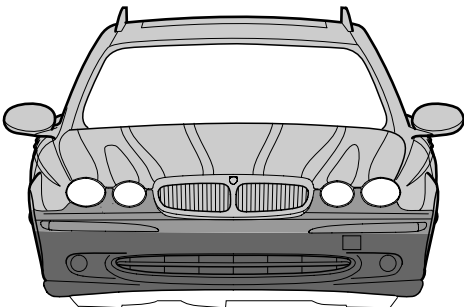
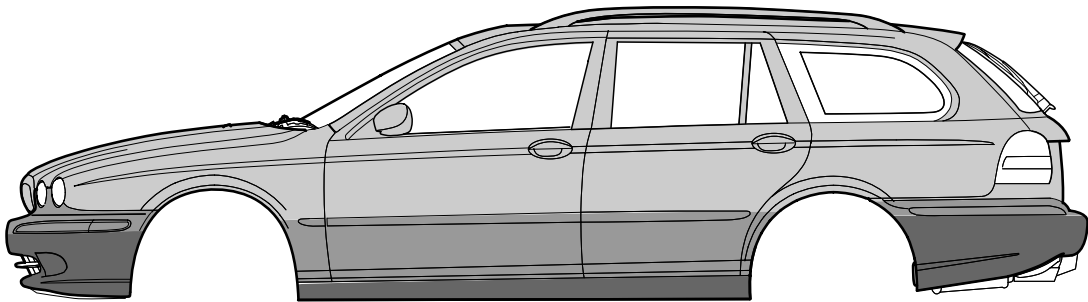
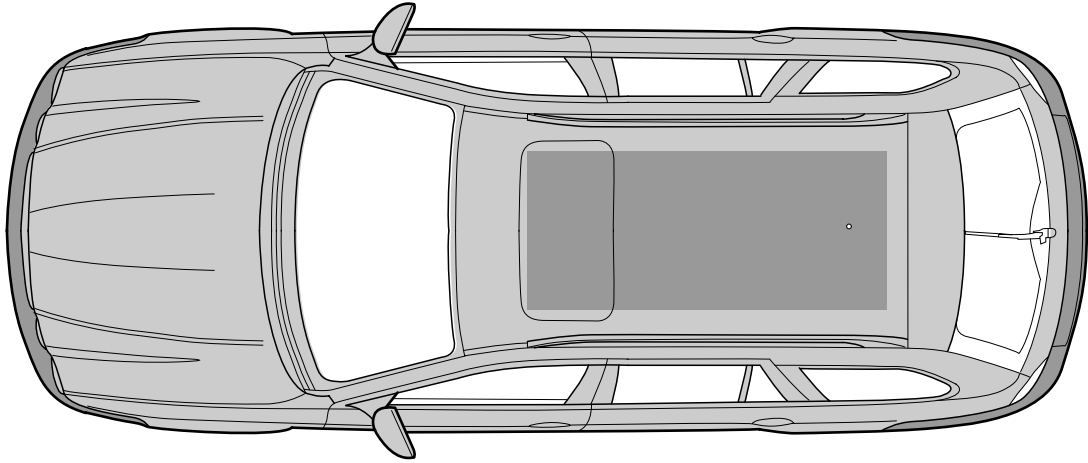

The shaded areas on the diagrams relate to the following zones:

'A' ZONE

High visibility

'B' ZONE

Medium to Low visibility

'C' ZONE

Low to hidden visibility

S-TYPE - Model Range

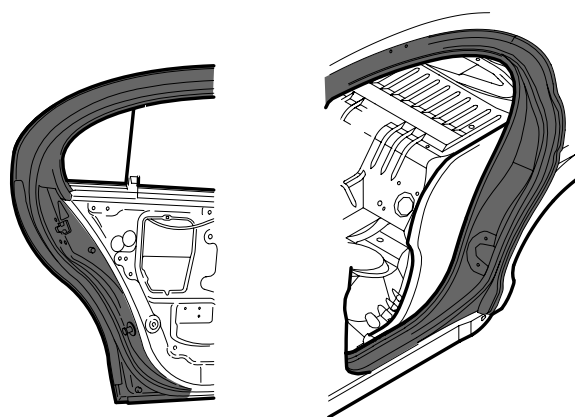
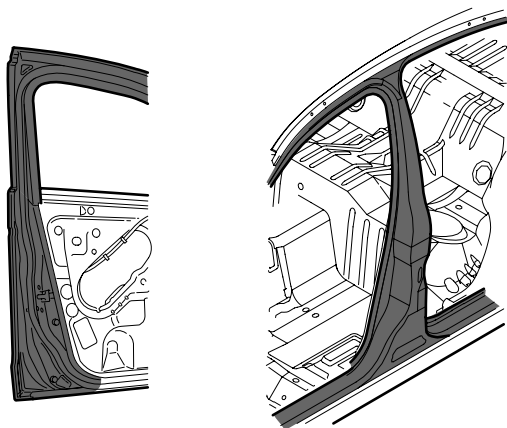
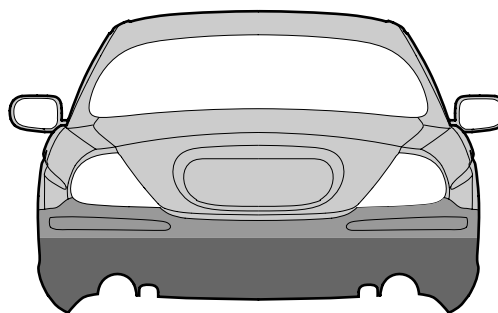
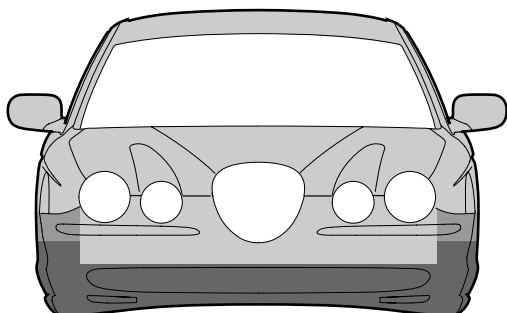
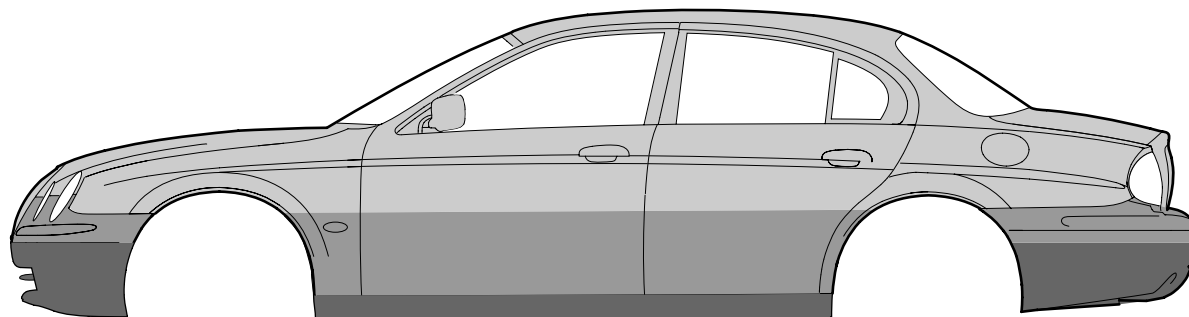
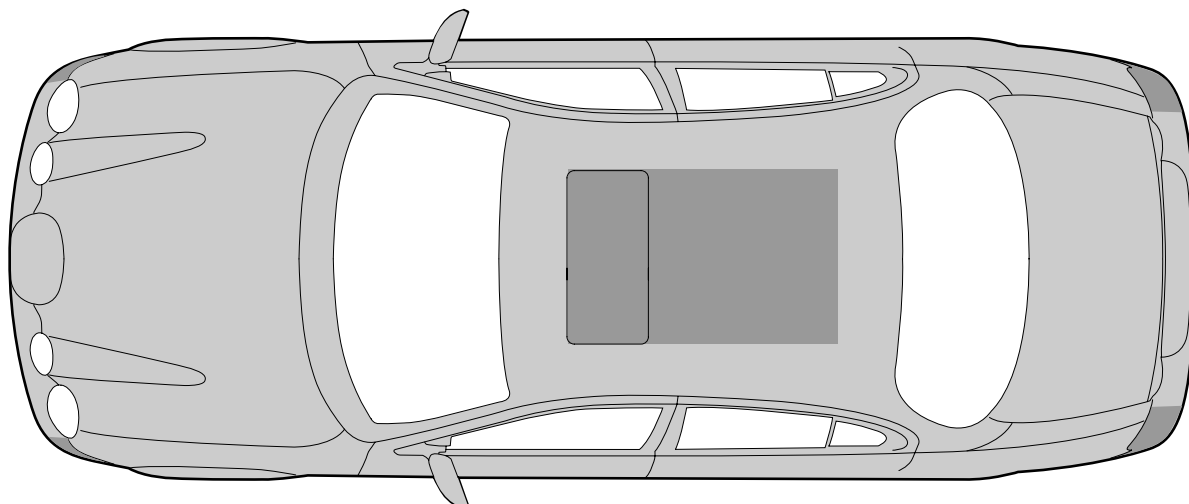

The shaded areas on the diagrams relate to the following zones:

'A' ZONE

High visibility

'B' ZONE

Medium to Low visibility

'C' ZONE

Low to hidden visibility

501.2684

XJ - Model Range

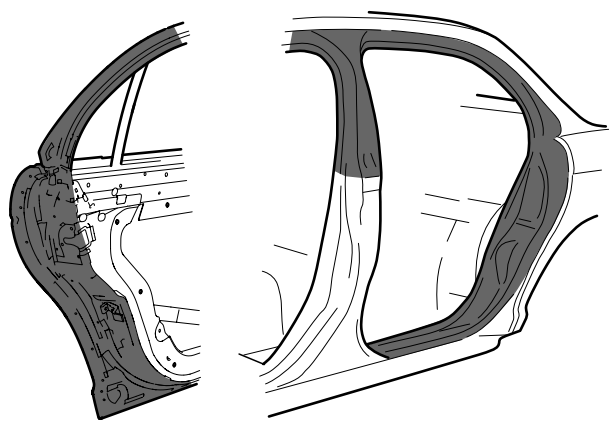
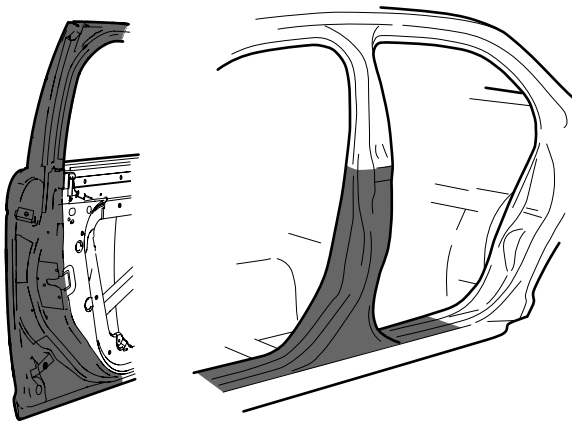
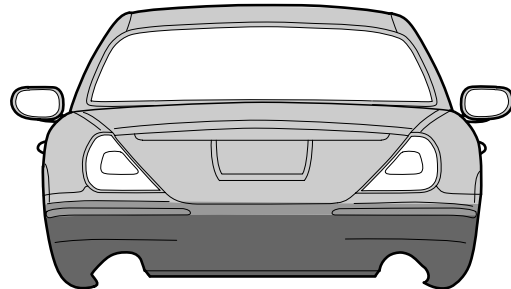
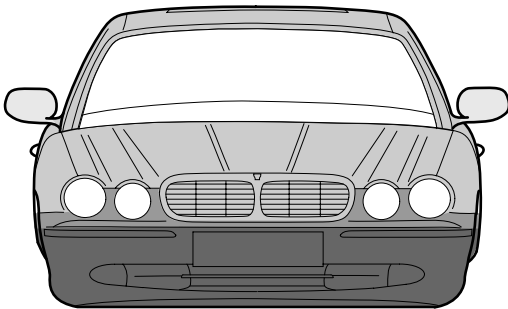
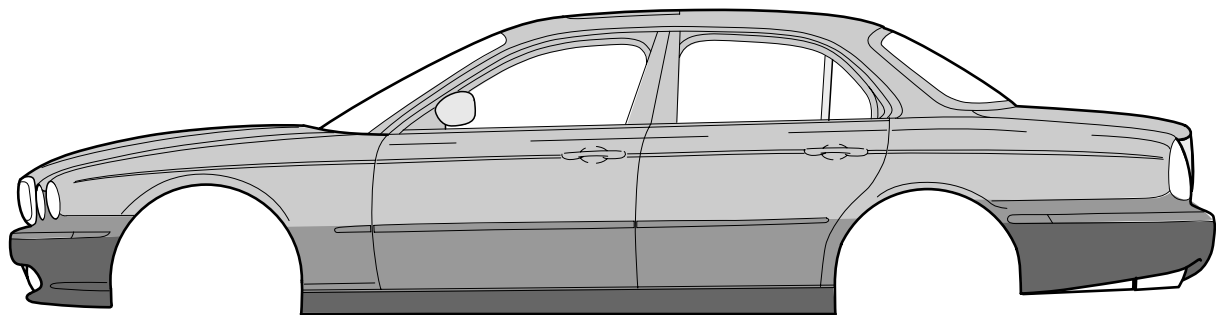
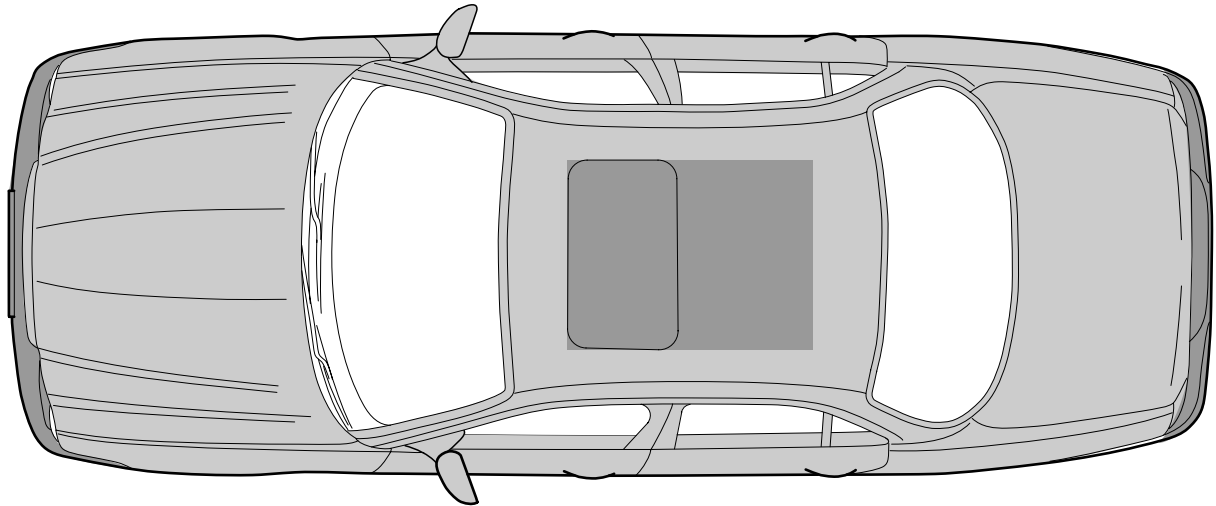

The shaded areas on the diagrams relate to the following zones:

'A' ZONE High visibility

'B' ZONE Medium to Low visibility

'C' ZONE Low to hidden visibility

501.2685

XK - Model Range

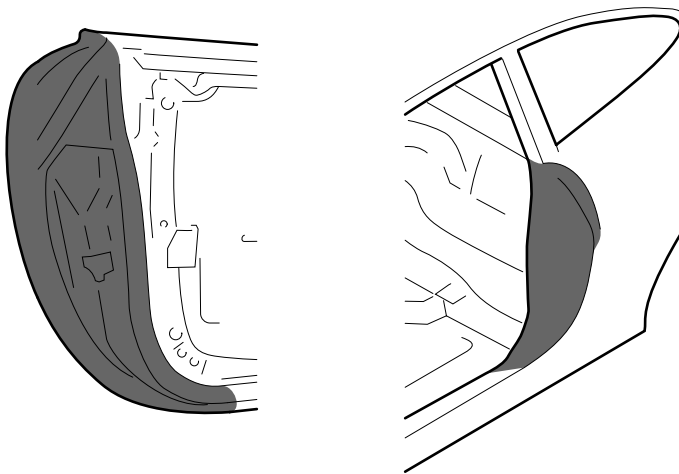
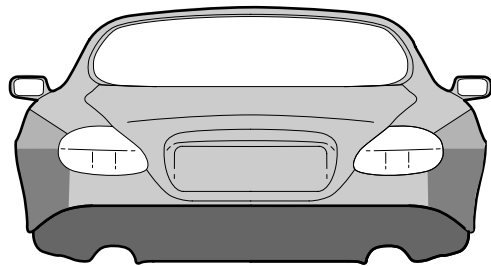
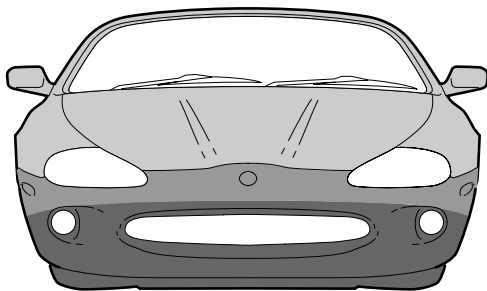
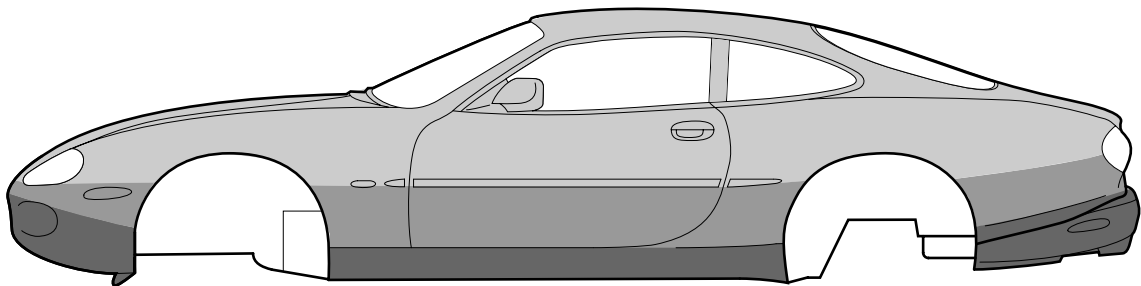
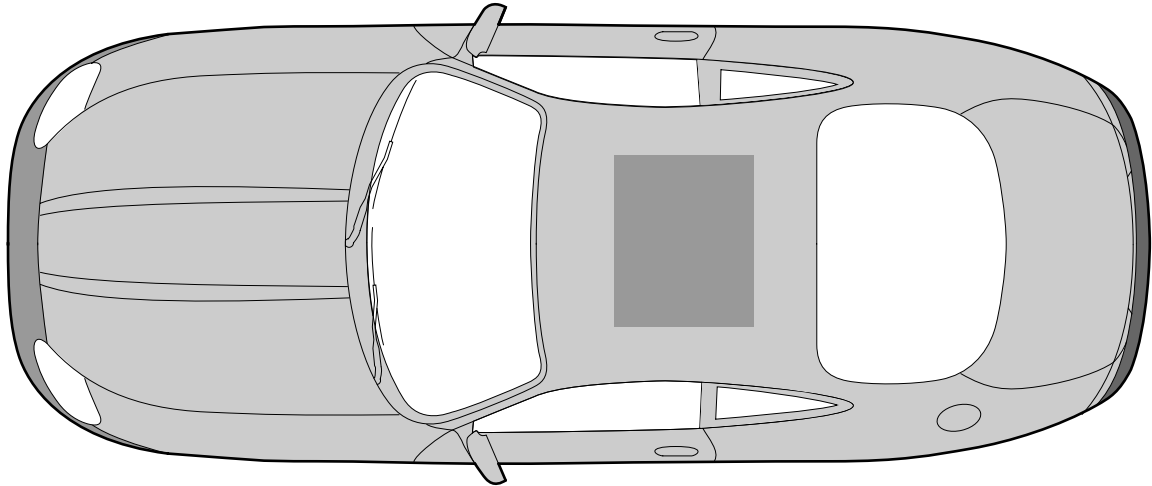

The shaded areas on the diagrams relate to the following zones:

'A' ZONE High visibility

'B' ZONE Medium to Low visibility

'C' ZONE Low to hidden visibility

FREELANDER - Model Range

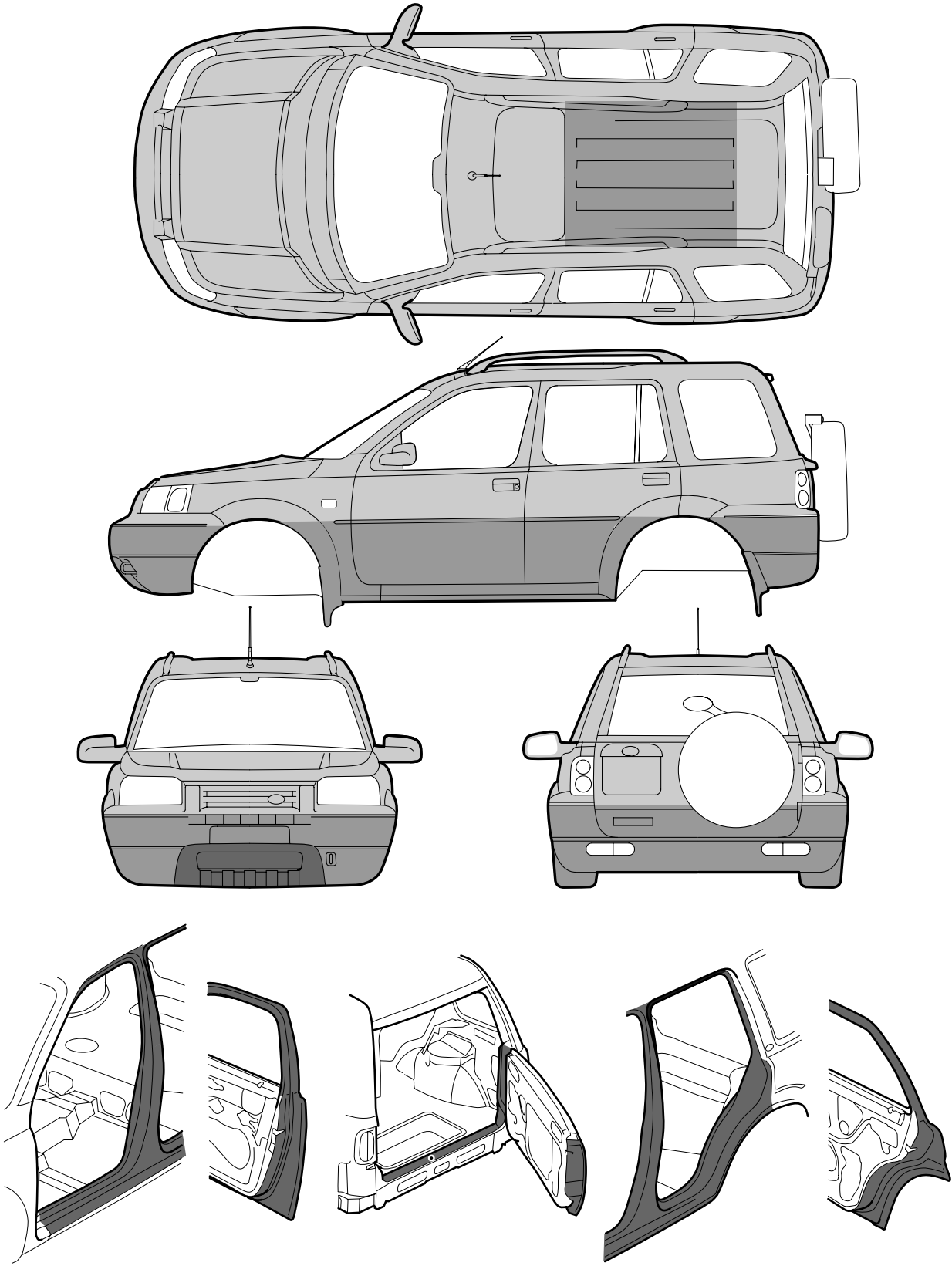

The shaded areas on the diagrams relate to the following zones:

'A' ZONE

High visibility

'B' ZONE

Medium to Low visibility

'C' ZONE

Low to hidden visibility

DISCOVERY 3 - Model Range

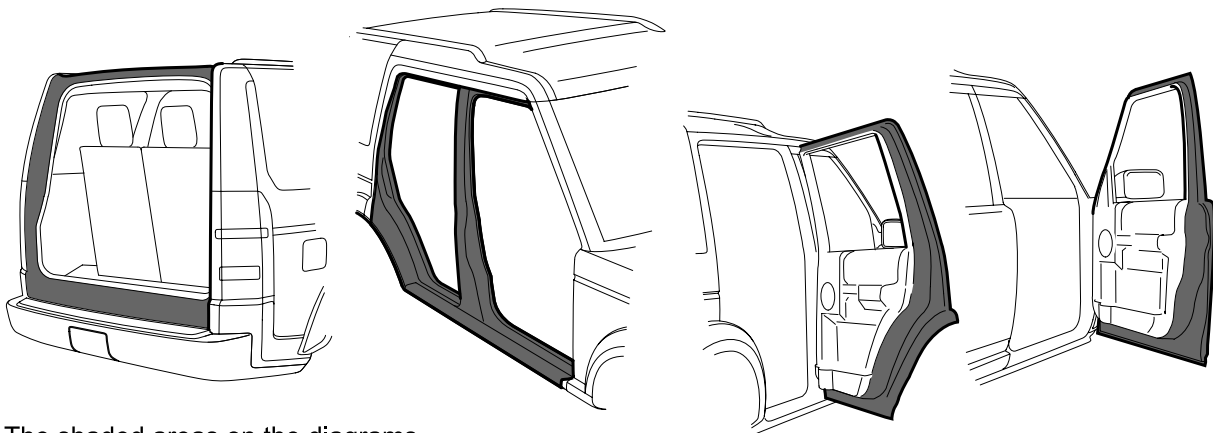
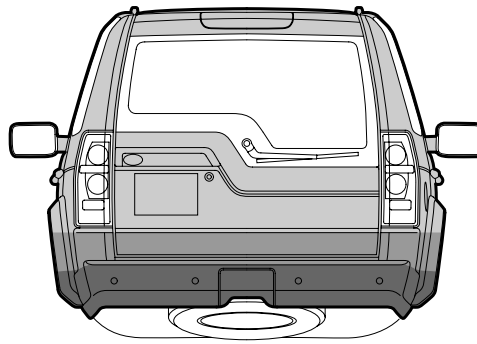
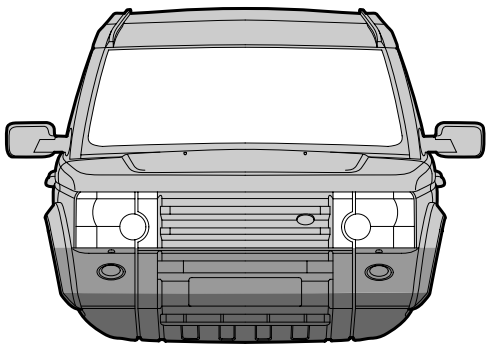
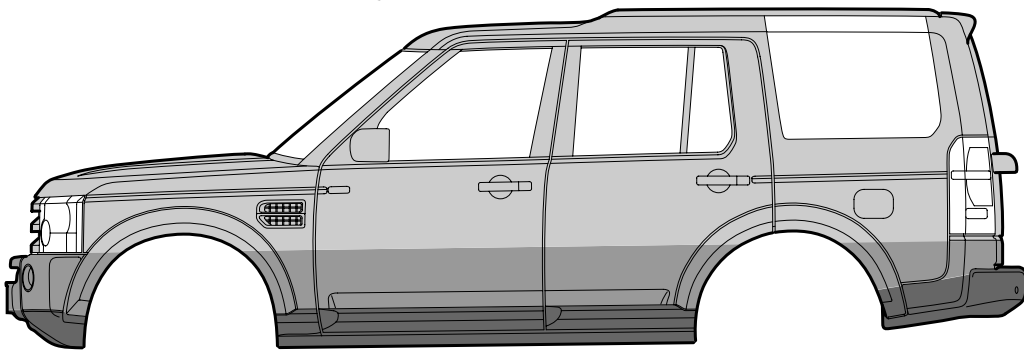
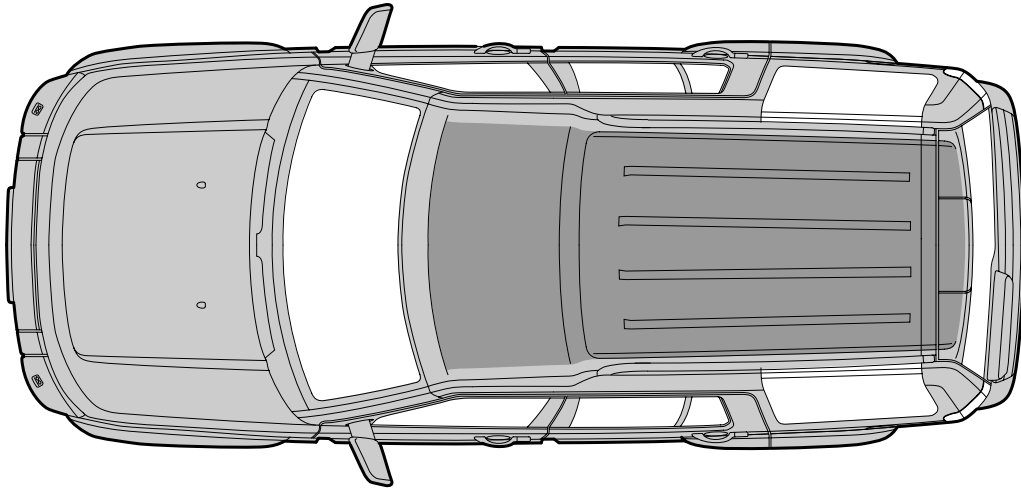

The shaded areas on the diagrams relate to the following zones:

'A' ZONE

High visibility

'B' ZONE

Medium to Low visibility

'C' ZONE

Low to hidden visibility

RANGE ROVER - Model Range

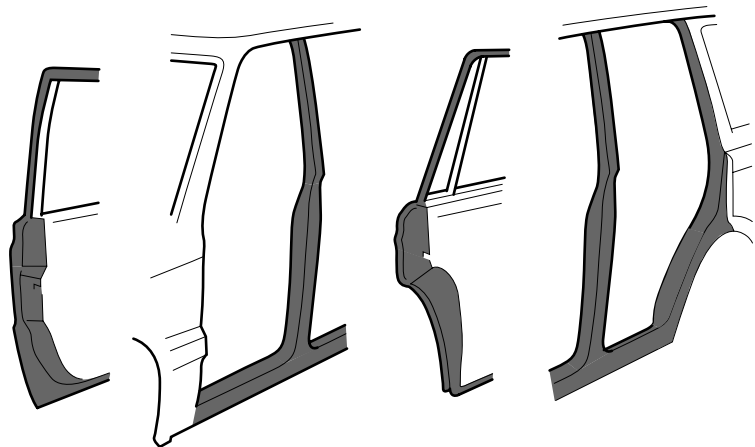
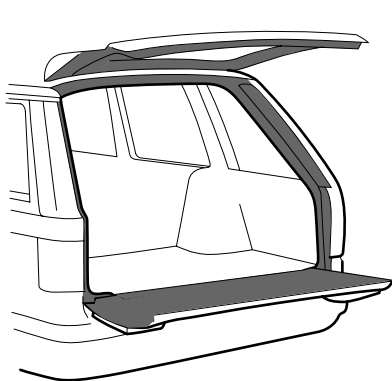
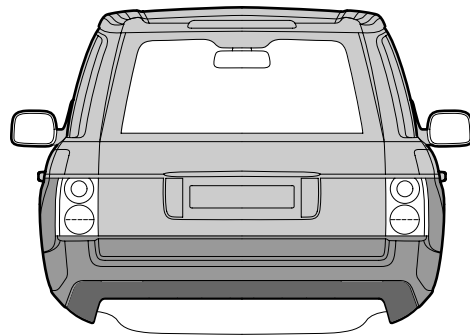
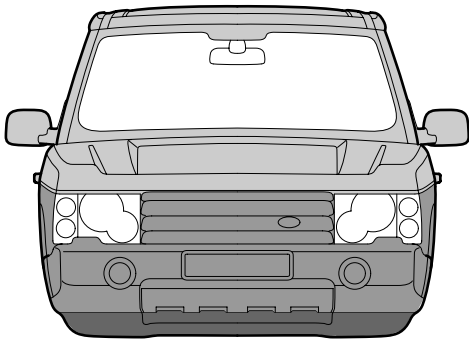
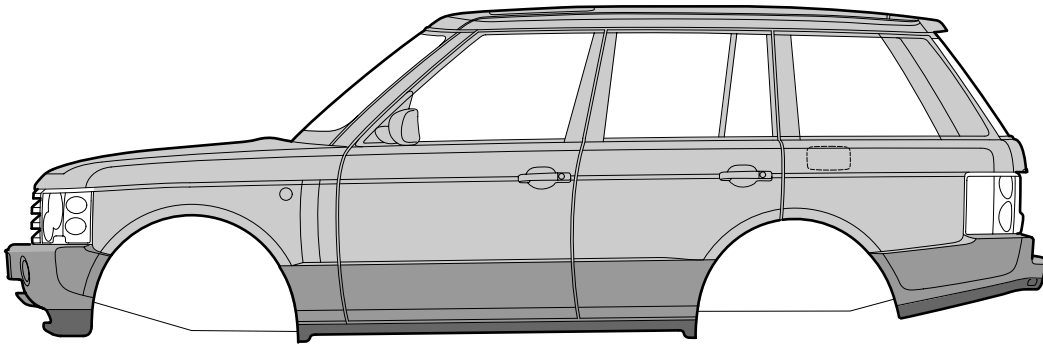
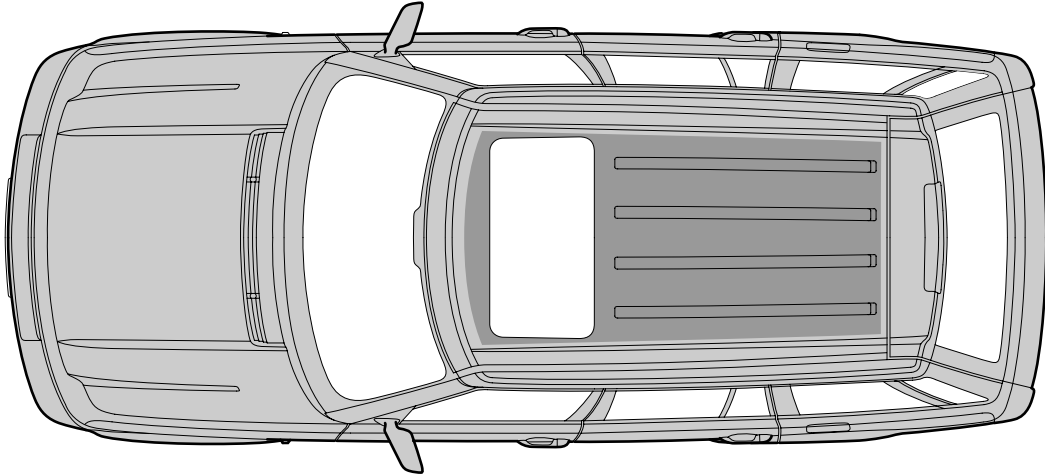

The shaded areas on the diagrams relate to the following zones:

'A' ZONE High visibility

'B' ZONE Medium to Low visibility

'C' ZONE Low to hidden visibility

RANGE ROVER SPORT - Model Range

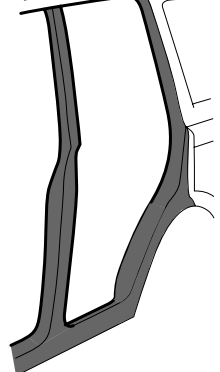
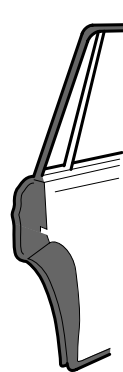
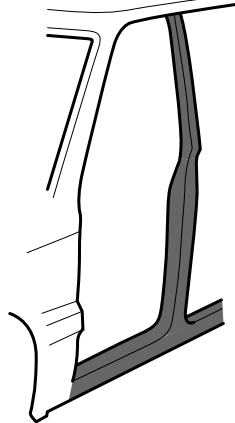
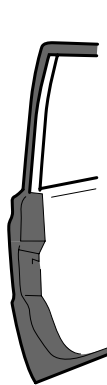
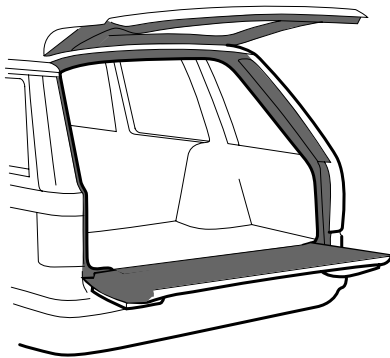
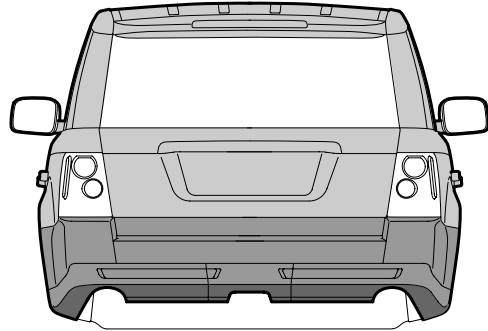
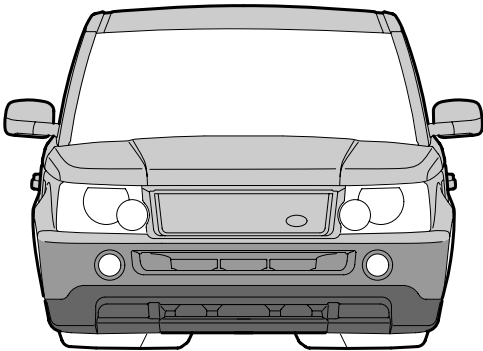
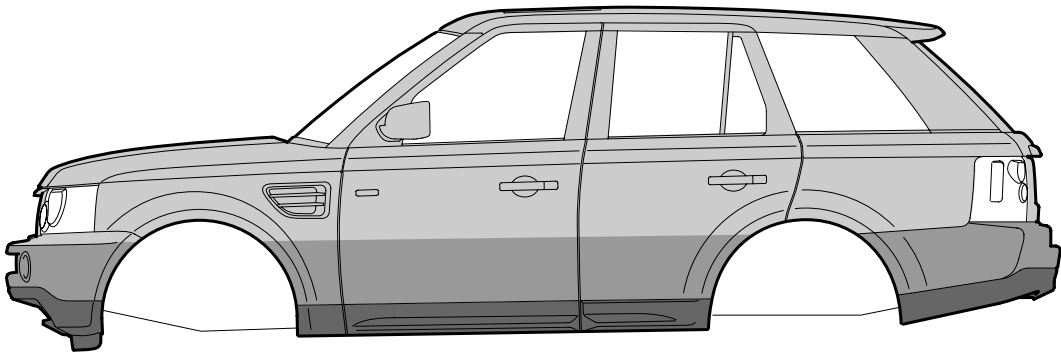
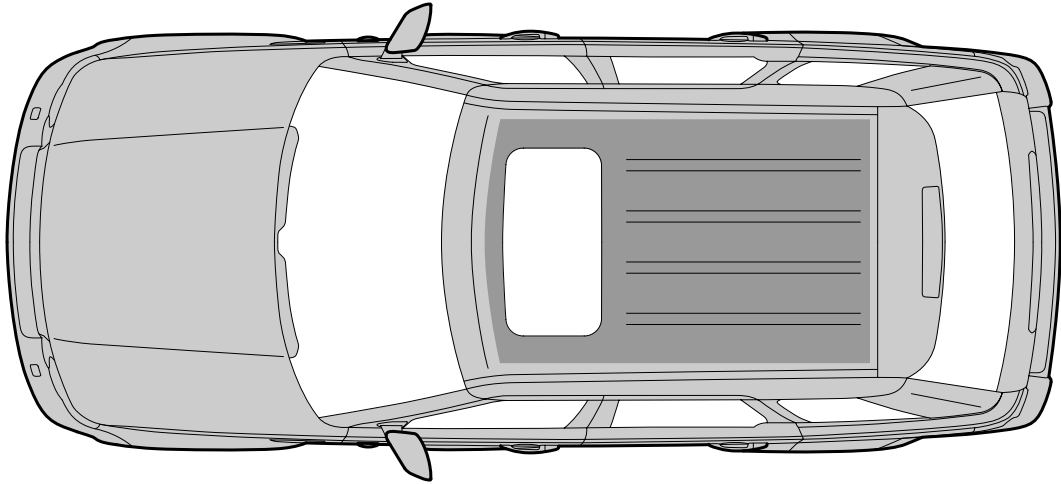

The shaded areas on the diagrams relate to the following zones:

'A' ZONE High visibility

'B' ZONE Medium to Low visibility

'C' ZONE Low to hidden visibility