

# Connection

Antenna cord is used when receiving a radio station with the built-in tuner. In this case, set "TUNER source" in <System Setup> (page 60) to "On".

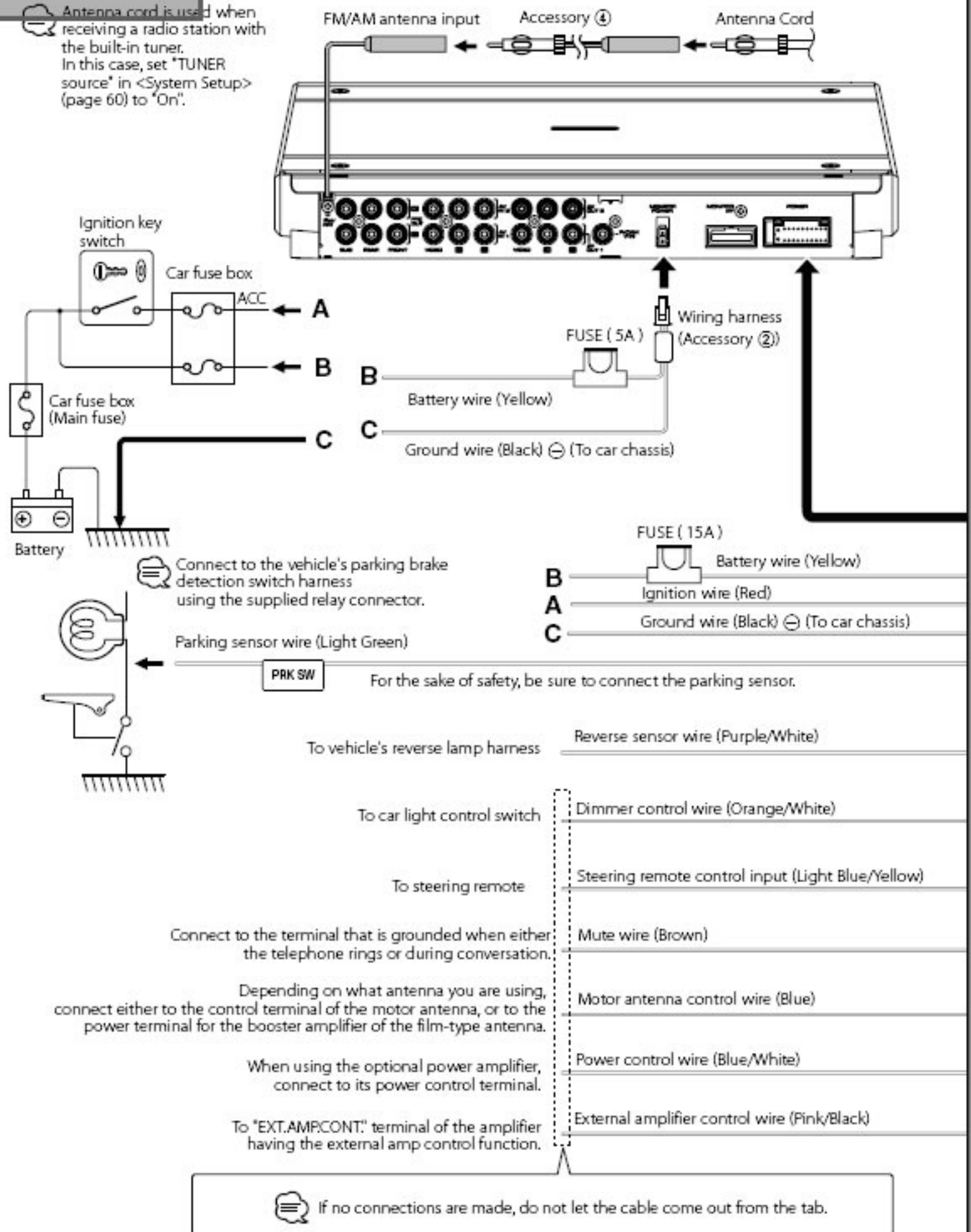

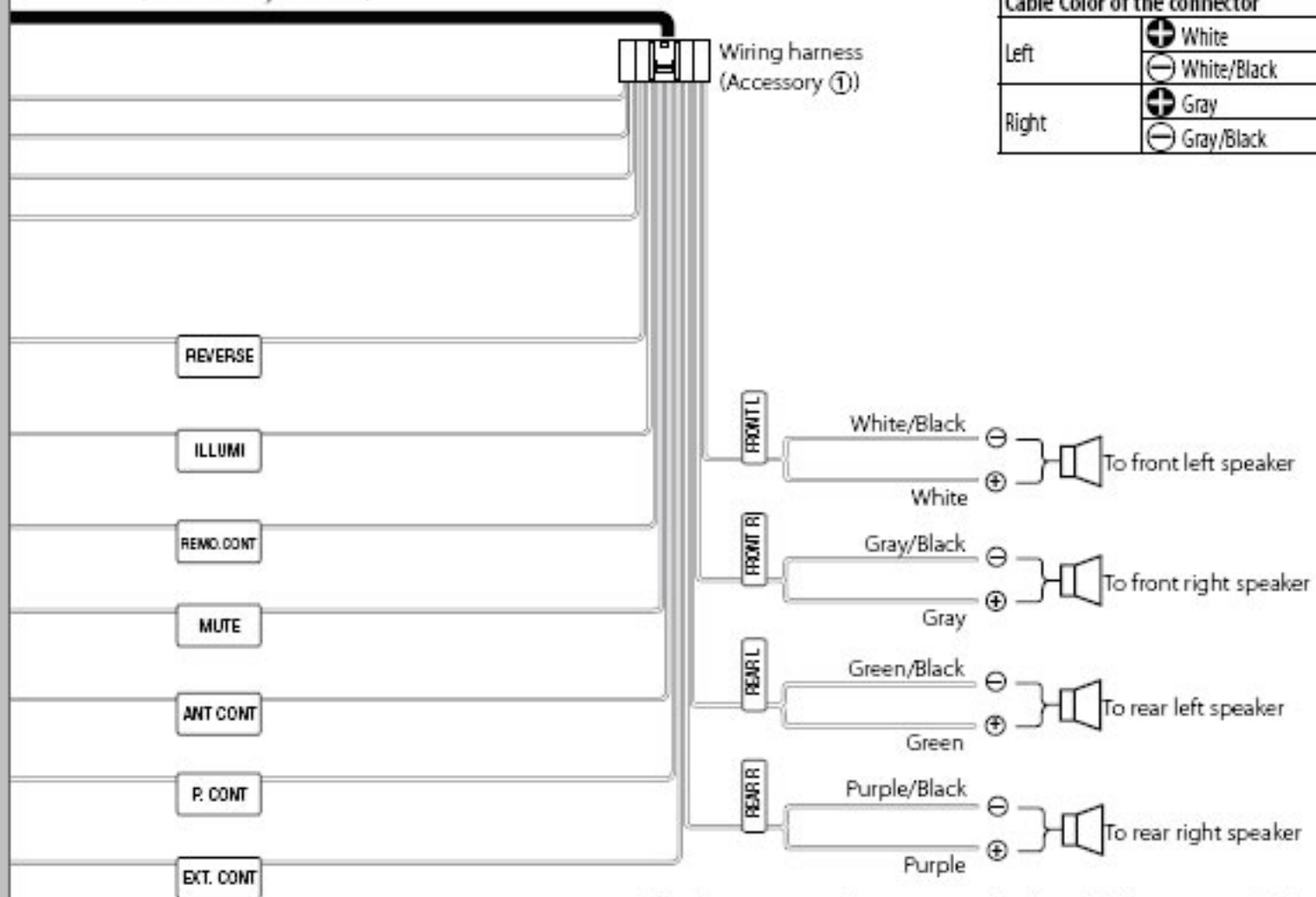
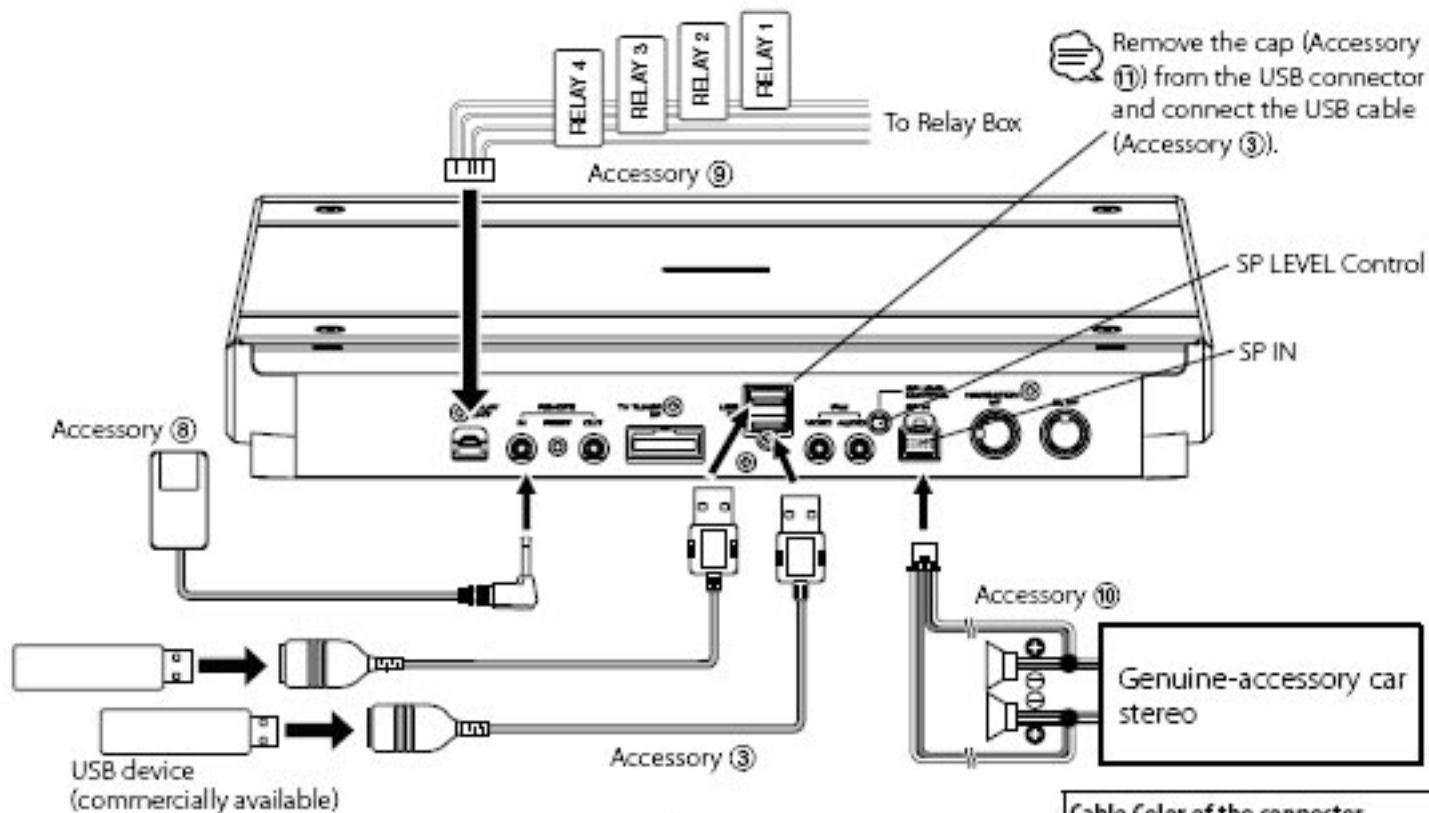

Cable Color of the connector	
Left	⊕ White
	⊖ White/Black
Right	⊕ Gray
	⊖ Gray/Black

**⚠** If you connect the ignition wire (red) and the battery wire (yellow) to the car chassis (ground), you may cause a short circuit, that in turn may start a fire. Always connect those wires to the power source running through the fuse box.

# System Connection

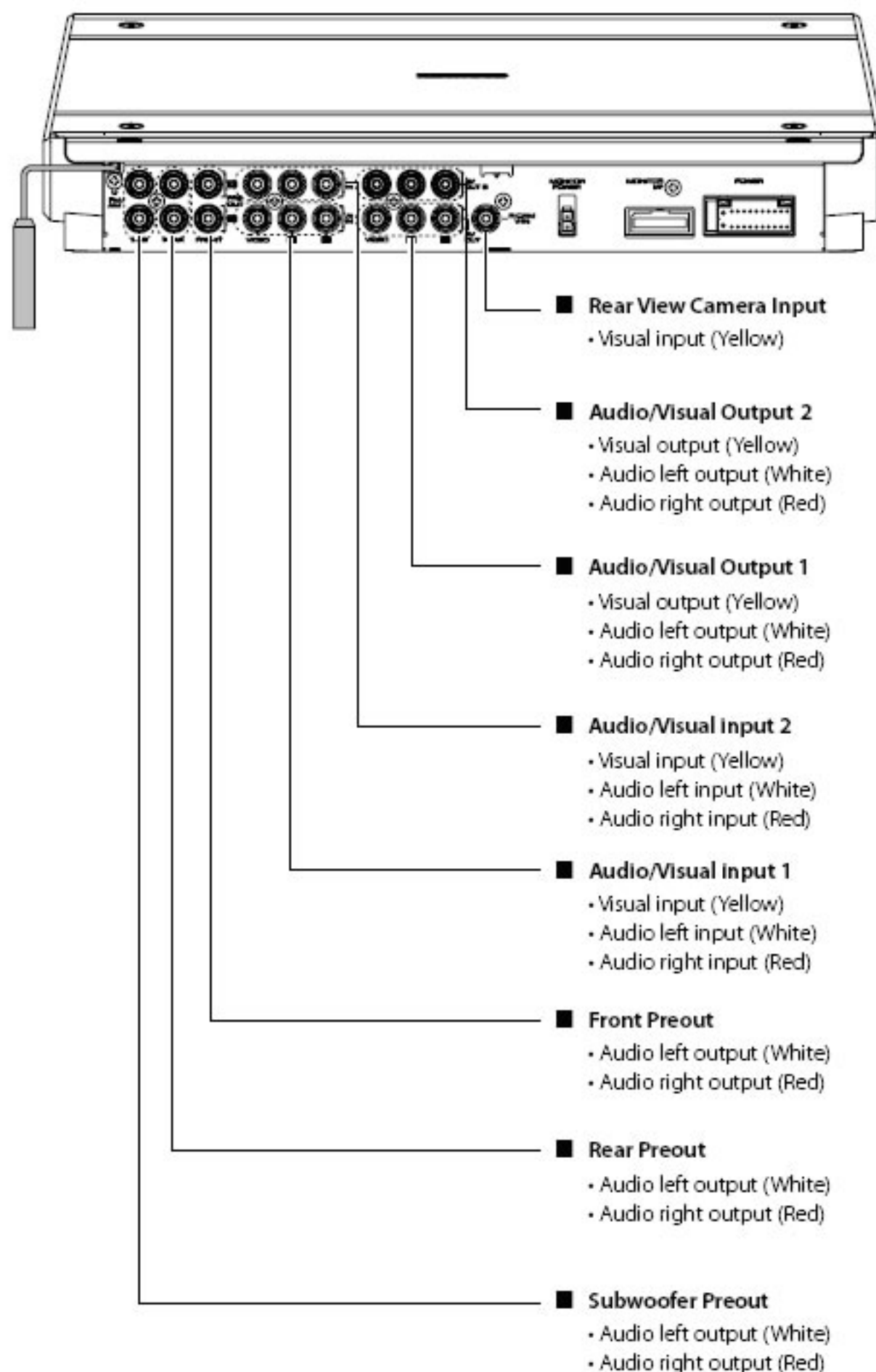

- **Rear View Camera Input**
  - Visual input (Yellow)
- **Audio/Visual Output 2**
  - Visual output (Yellow)
  - Audio left output (White)
  - Audio right output (Red)
- **Audio/Visual Output 1**
  - Visual output (Yellow)
  - Audio left output (White)
  - Audio right output (Red)
- **Audio/Visual Input 2**
  - Visual input (Yellow)
  - Audio left input (White)
  - Audio right input (Red)
- **Audio/Visual Input 1**
  - Visual input (Yellow)
  - Audio left input (White)
  - Audio right input (Red)
- **Front Preout**
  - Audio left output (White)
  - Audio right output (Red)
- **Rear Preout**
  - Audio left output (White)
  - Audio right output (Red)
- **Subwoofer Preout**
  - Audio left output (White)
  - Audio right output (Red)

# Optional Accessory Connection

