

22-20486-A-A01-01-0404a (3.315-15M) (P)

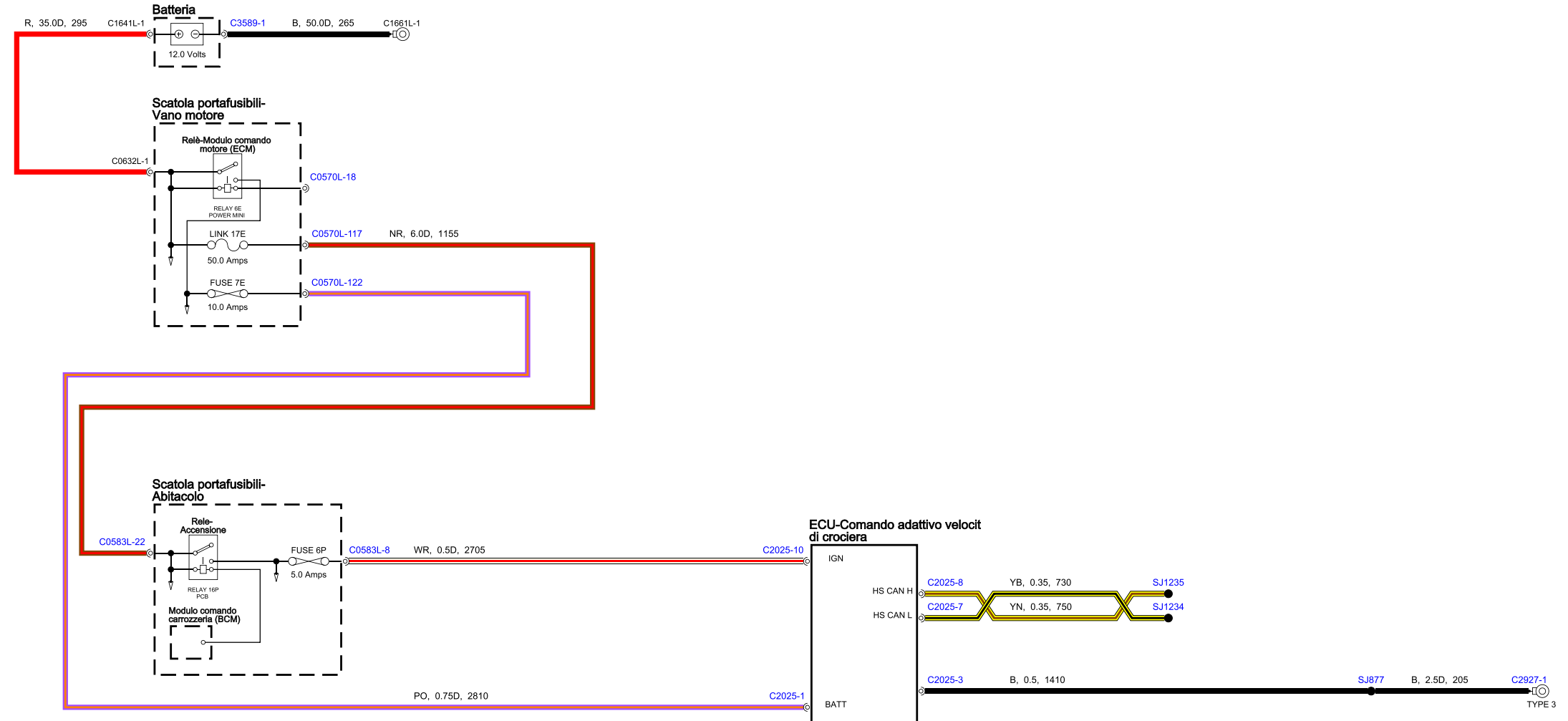

02/70016-E-A-01-04-Italian (3/10/1807-PP)

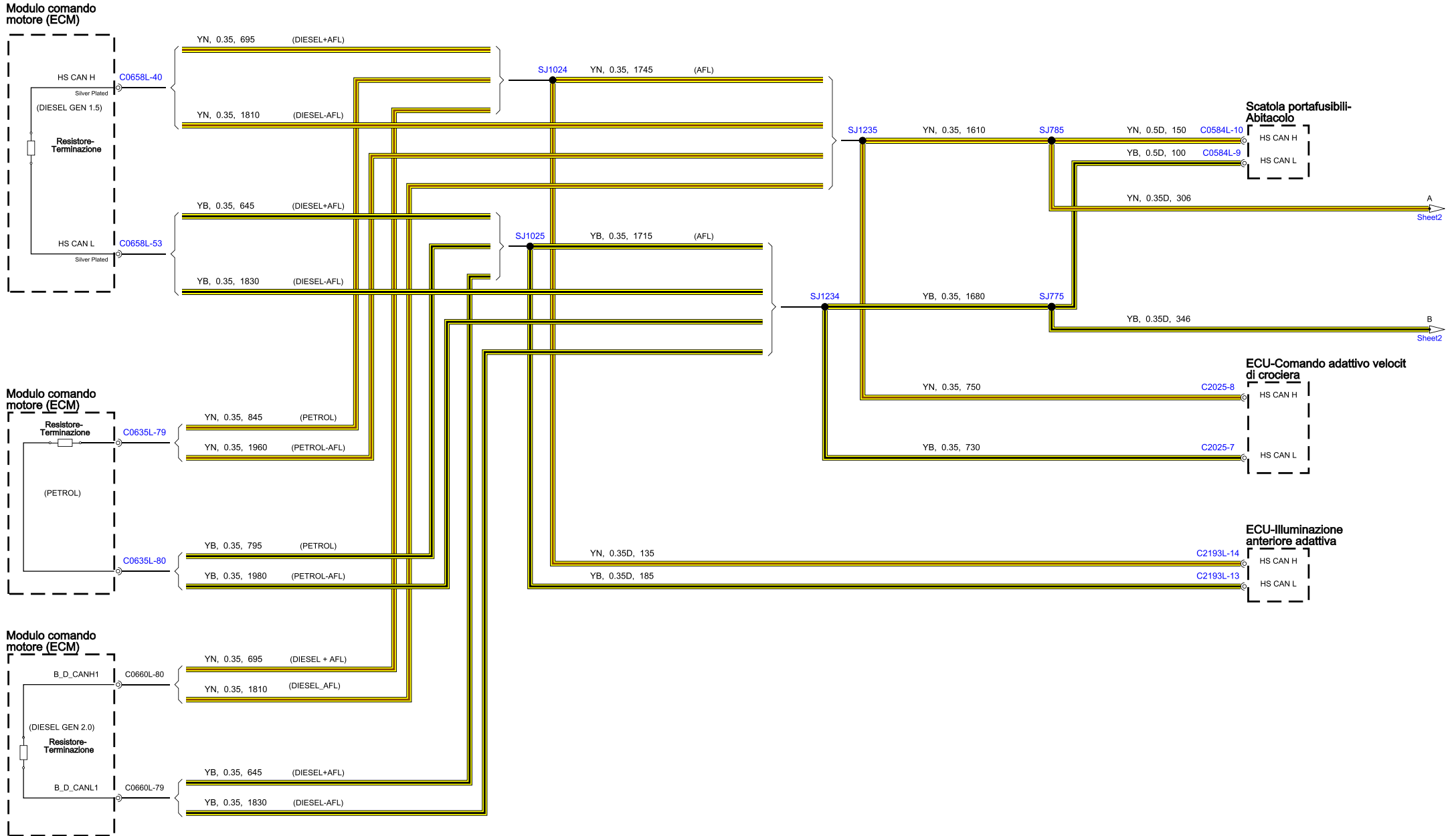

22/10/2015, 8:44:40, 47/10/15, 0,319, 1004/2/15

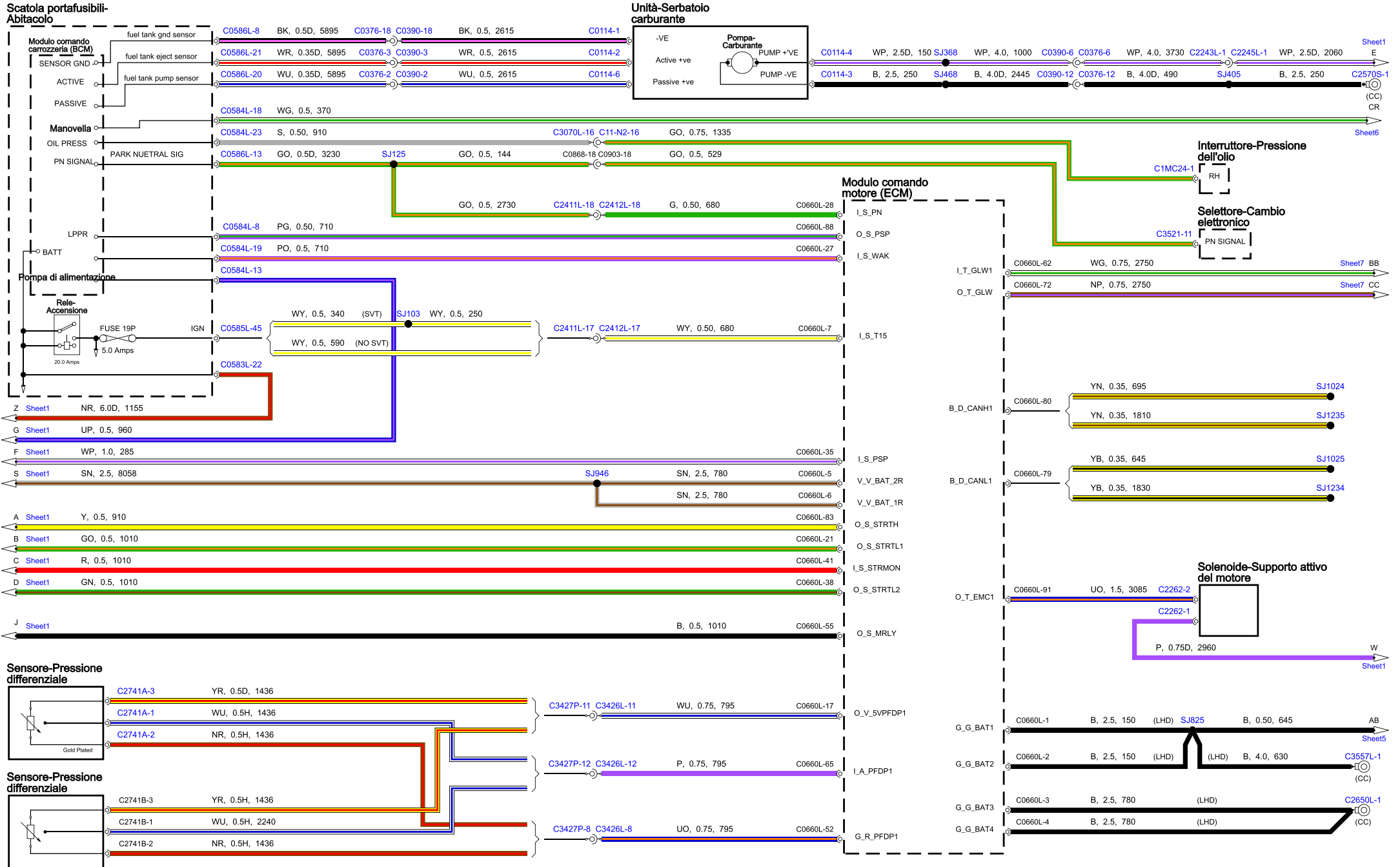

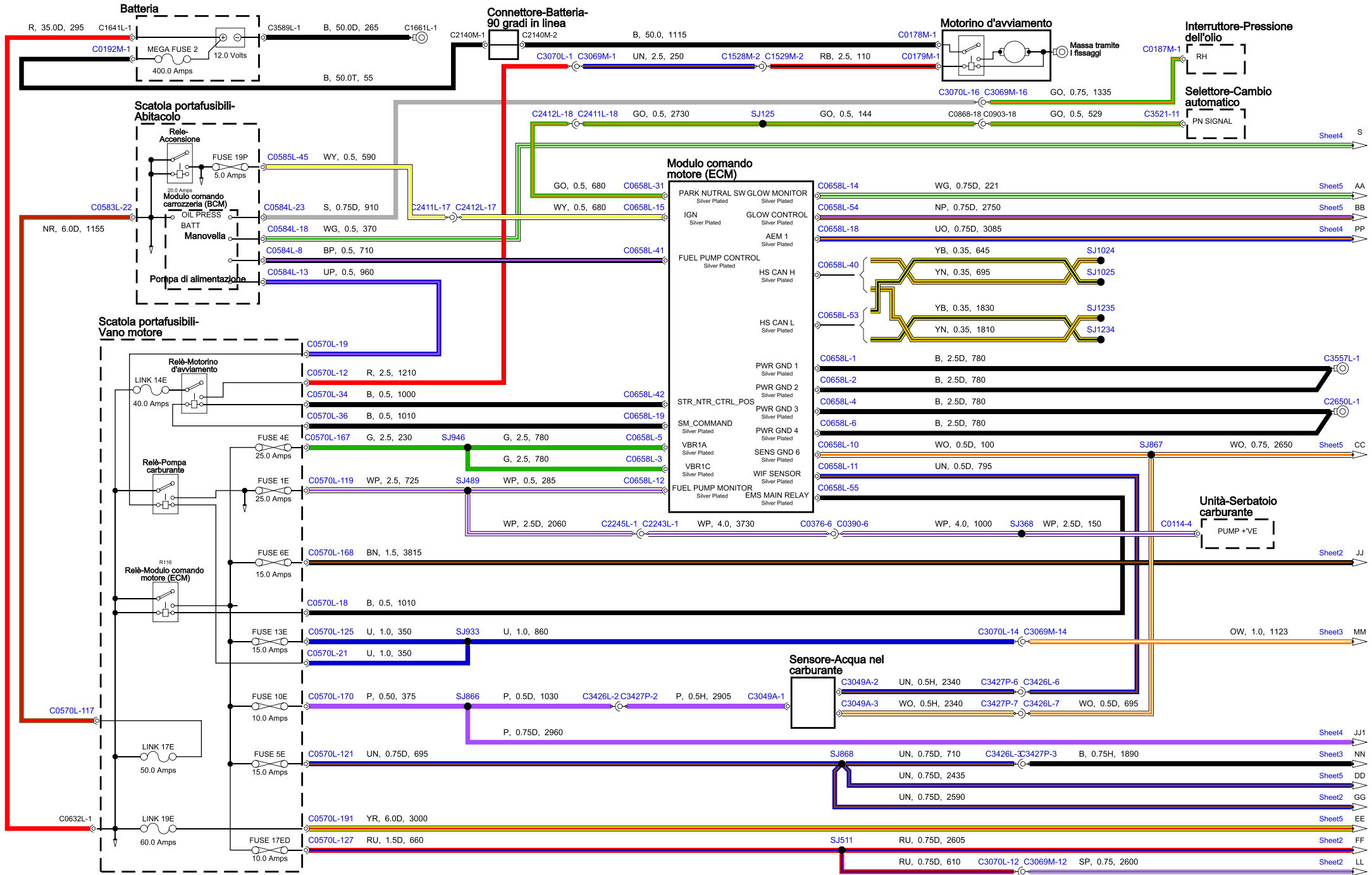

[Cliccare qui per stampare](#)

Connettore: **C2025**

ALLOGGIAMENTO DEL CONNETTORE RIPARABILE

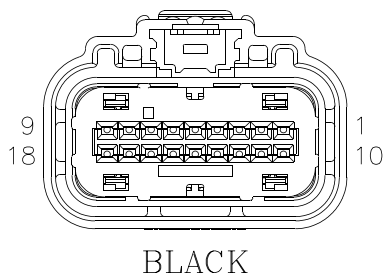

Descrizione: ECU-Comando adattivo velocit di crociera

Ubicazione: Dietro il centro del paraurti anteriore

Qualifier:

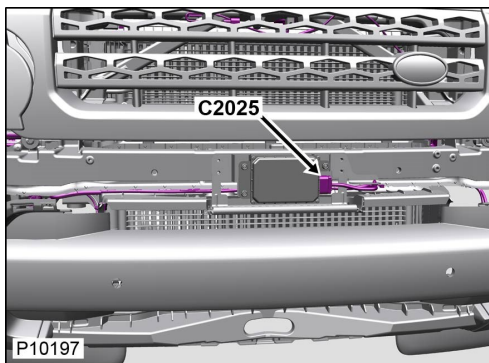

Numero parte progettazione: **4R3T-14A464-AB-014**

Numero parte ricambio:

Colore: **BLACK**

Cavità: **18WY**

Cablaggio: **ENGINE COMPARTMENT HARNESS**

Informazioni per la riparazione e tabella cavi

CAV	CSA	COL	CCT	DESTN	Cavo precablato	Estrattore	Applicatore	Pinza spelafili	Manicotto termorestringente	ID	Giunzione
1	0.75D	PO	405L	Co570L	418-235	418-595	418-116A	418-117	418-104	418-112	418-107
1	0.75D	PO	405R	Co570R	418-235	418-595	418-116A	418-117	418-104	418-112	418-107
3	0.5D	B	405	S/JOINT SJ877	418-235	418-595	418-116A	418-117	418-104	418-112	418-107
7	0.35D	YB	405L	S/JOINT SJ1234	418-411-45	418-595	418-116A	418-117	418-104	418-112	418-107
7	0.35D	YB	405R	S/JOINT SJ1234	418-411-45	418-595	418-116A	418-117	418-104	418-112	418-107
8	0.35D	YN	405L	S/JOINT SJ1235	418-411-45	418-595	418-116A	418-117	418-104	418-112	418-107
8	0.35D	YN	405R	S/JOINT SJ1235	418-411-45	418-595	418-116A	418-117	418-104	418-112	418-107
10	0.5D	WR	405L	Co583L	418-235	418-595	418-116A	418-117	418-104	418-112	418-107
10	0.5D	WR	405R	Co583R	418-235	418-595	418-116A	418-117	418-104	418-112	418-107

Connettore: **C2025**

ALLOGGIAMENTO DEL CONNETTORE RIPARABILE

Descrizione: ECU-Comando adattivo velocit di crociera

Ubicazione: Dietro il centro del paraurti anteriore

Qualifier:

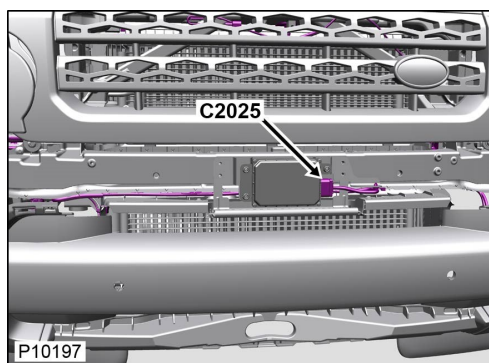

[Cliccare qui per stampare](#)

Connettore: **C0570R**

NON RIPARABILE

Descrizione: **Scatola portafusibili-Vano motore**

Ubicazione: **Lato sinistro posteriore del vano motore**

Qualifier: **Condizione guida destra mostrata**

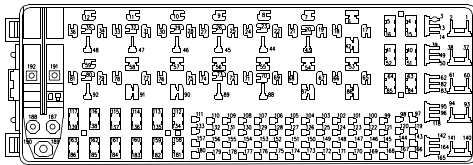

BLACK

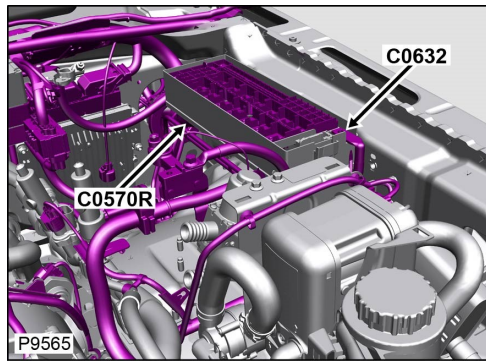

Numero parte progettazione: **CHCT-14A094-FA**

Numero parte ricambio:

Colore: **BLACK**

Cavità: **194WY**

Cablaggio: **ENGINE COMPARTMENT HARNESS**

Informazioni per la riparazione e tabella cavi

CAV	CSA	COL	CCT	DESTN	Cavo precablato	Estrattore	Applicatore	Pinza spelafili	Manicotto termorestringente	ID	Giunzione
2	2.5D	R	885R	S/JOINT SJ1014	418-587-15	418-595	418-116A	418-117	418-104	418-113	418-108
3	0.5D	B	885R	S/JOINT SJ173	418-412	418-595	418-116A	418-117	418-104	418-112	418-107
8	4.0D	NU	21R	C2410R	418-411	418-593	418-116A	418-117	418-104	418-114	418-109
10	0.75D	PW	252R	C2725R	418-587-16	418-593	418-116A	418-117	418-104	418-112 418-114	418-107
10	1.5D	WR	798R	C3070R	418-410	418-593	418-116A	418-117	418-104	418-113	418-108
11	4.0D	NR	200R	C2996R	418-411	418-593	418-116A	418-117	418-104	418-114	418-109
12	2.5D	R	252R	S/JOINT SJ1207	418-410	418-593	418-116A	418-117	418-104	418-113	418-108
12	2.5D	R	1145R	C3070R	418-410	418-593	418-116A	418-117	418-104	418-113	418-108
12	2.5D	R	1147R	S/JOINT SJ141	418-410	418-593	418-116A	418-117	418-104	418-113	418-108
14	0.5D	LG	885R	S/JOINT SJ1947	418-412	418-595	418-116A	418-117	418-104	418-112	418-107
18	0.5D	B	252R	C0635R	418-587-16	418-593	418-116A	418-117	418-104	418-112 418-114	418-107
18	0.5D	B	1145R	C0658R	418-587-16	418-593	418-116A	418-117	418-104	418-112 418-114	418-107
										418-112	

64	4.0D	PK	109R	C2244R	418-587-06	-	418-116A	418-117	418-104	418-114	418-109
65	0.5D	BY	419R	C2321R	418-587-16	418-593	418-116A	418-117	418-104	418-112 418-114	418-107
66	0.5D	R	419R	C2321R	418-587-16	418-593	418-116A	418-117	418-104	418-112 418-114	418-107
67	0.5D	N	109R	Co584R	418-587-16	418-593	418-116A	418-117	418-104	418-112 418-114	418-107
68	0.5D	LG	109R	S/JOINT SJ1947	418-587-16	418-593	418-116A	418-117	418-104	418-112 418-114	418-107
69	0.5D	B	200R	S/JOINT SJ171	418-587-16	418-593	418-116A	418-117	418-104	418-112 418-114	418-107
71	0.5D	RO	200R	C2244R	418-587-16	418-593	418-116A	418-117	418-104	418-112 418-114	418-107
72	0.5D	R	200R	Co584R	418-587-16	418-593	418-116A	418-117	418-104	418-112 418-114	418-107
73	1.0D	B	200R	C2926R	418-587-16	418-593	418-116A	418-117	418-104	418-112 418-114	418-107
75	0.75D	N	252R	S/JOINT SJ1013	418-587-16	418-593	418-116A	418-117	418-104	418-112 418-114	418-107
76	0.5D	B	252R	Co635R	418-587-16	418-593	418-116A	418-117	418-104	418-112 418-114	418-107
76	1.0D	NW	1140R	Co660R	418-587-16	418-593	418-116A	418-117	418-104	418-112 418-114	418-107
77	0.5D	SO	1148R	C3070R	418-587-16	418-593	418-116A	418-117	418-104	418-112 418-114	418-107
77	0.5D	SO	1098R	Co635R	418-587-16	418-593	418-116A	418-117	418-104	418-112 418-114	418-107
77	0.5D	Y	1149R	S/JOINT SJ142	418-587-16	418-593	418-116A	418-117	418-104	418-112 418-114	418-107

78	0.5D	Y	1098R	Co635R	418-587-16	418-593	418-116A	418-117	418-104	418-112 418-114	418-107
78	0.5D	Y	1148R	S/JOINT SJ1208	418-587-16	418-593	418-116A	418-117	418-104	418-112 418-114	418-107
78	0.5D	GN	1149R	Co660R	418-587-16	418-593	418-116A	418-117	418-104	418-112 418-114	418-107
80	2.5D	B	183R	S/JOINT SJ879	418-410	418-593	418-116A	418-117	418-104	418-113	418-108
81	0.5D	GR	183R	Co584R	418-587-16	418-593	418-116A	418-117	418-104	418-112 418-114	418-107
83	1.0D	B	200R	S/JOINT SJ173	418-412	418-595	418-116A	418-117	418-104	418-112	418-107
85	6.0D	PS	109R	S/JOINT SJ1000	418-419	-	418-116A	418-117	418-104	418-114	418-109
87	6.0D	PW	109R	Co570R	418-417	-	418-116A	418-117	418-104	-	-
91	4.0D	RU	1096R	C3842R	418-499	418-595	418-116A	418-117	418-105	418-114	418-109
92	2.5D	RLG	183R	Co828	418-410	418-593	418-116A	418-117	418-104	418-113	418-108
94	1.5D	NY	113R	Co570R	418-587-15	418-595	418-116A	418-117	418-104	418-113	418-108
95	0.5D	LG	572R	S/JOINT SJ1947	418-412	418-595	418-116A	418-117	418-104	418-112	418-107
98	2.5D	NR	419R	S/JOINT SJ1572	418-096	418-595	418-116A	418-117	418-104	418-113	418-108
106	0.75D	O	377R	C3058R	418-416	418-595	418-116A	418-117	418-104	418-112	418-107
107	0.75D	R	413R	Co506R	418-416	418-595	418-116A	418-117	418-104	418-112	418-107
108	2.5D	NG	413R	Co506R	418-096	418-595	418-116A	418-117	418-104	418-113	418-108
110	1.5D	UG	200R	Co570R	418-096	418-595	418-116A	418-117	418-104	418-113	418-108
113	4.0D	R	413R	Co506R	418-587-06	-	418-116A	418-117	418-104	418-114	418-109
114	4.0D	NP	200R	C2245R	418-587-06	-	418-116A	418-117	418-104	418-114	418-109
115	4.0D	PU	200R	C2410R	418-587-06	-	418-116A	418-117	418-104	418-114	418-109
116	4.0D	NU	200R	Co583R	418-587-06	-	418-116A	418-117	418-104	418-114	418-109
117	6.0D	NR	200R	Co583R	418-419	-	418-116A	418-117	418-104	418-	418-109

167	2.5D	G	1145R	S/JJOINT SJ1946	418-096	418-595	418-116A	418-117	418-104	418-113	418-108
167	2.5D	RW	252R	C2725R	418-096	418-595	418-116A	418-117	418-104	418-113	418-108
168	1.5D	BN	1145R	S/JJOINT SJ630	418-096	418-595	418-116A	418-117	418-104	418-113	418-108
168	1.0D	N	252R	S/JJOINT SJ1013	418-416	418-595	418-116A	418-117	418-104	418-112	418-107
168	1.5D	PS	1147R	S/JJOINT SJ1118	418-096	418-595	418-116A	418-117	418-104	418-113	418-108
170	0.75D	P	254R	S/JJOINT SJ1866	418-416	418-595	418-116A	418-117	418-104	418-112	418-107
171	1.5D	NY	113R	S/JJOINT SJ170	418-096	418-595	418-116A	418-117	418-104	418-113	418-108
172	2.5D	WG	252R	C3424R	418-096	418-595	418-116A	418-117	418-104	418-113	418-108
173	0.5D	GN	200R	C2244R	418-521	418-595	418-116A	418-117	418-104	418-112	418-107
174	0.5D	WG	252R	Co635R	418-521	418-595	418-116A	418-117	418-104	418-112	418-107
174	0.5D	R	1147R	Co660R	418-521	418-595	418-116A	418-117	418-104	418-112	418-107
178	2.5D	PU	419R	C2321R	418-096	418-595	418-116A	418-117	418-104	418-113	418-108
179	4.0D	WY	1140R	C2244R	418-413	-	418-116A	418-117	418-104	418-114	418-109
180	1.5D	PY	200R	S/JJOINT SJ1062	418-096	418-595	418-116A	418-117	418-104	418-113	418-108
181	6.0D	GY	200R	C2293	418-419	-	418-116A	418-117	418-104	418-114	418-109
185	4.0D	NG	200R	Co583R	418-587-06	-	418-116A	418-117	418-104	418-114	418-109
186	6.0D	NS	200R	Co583R	418-419	-	418-116A	418-117	418-104	418-114	418-109
189	6.0D	PW	109R	Co570R	418-417	-	418-116A	418-117	418-104	-	-
191	6.0D	YR	254R	Co190	-	-	-	-	-	-	-
192	6.0D	R	200R	C2960R	-	-	-	-	-	-	-

Connettore: **Co570R**

NON RIPARABILE

Descrizione: **Scatola portafusibili-Vano motore**

Ubicazione: **Lato sinistro posteriore del vano motore**

Qualifier: **Condizione guida destra mostrata**

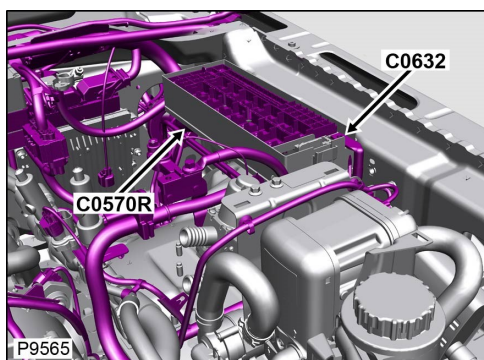

Numero parte progettazione: **CHCT-14A094-FA**

Numero parte ricambio:

Colore: **BLACK**

Cavità: **194WY**

Cablaggio: **ENGINE COMPARTMENT HARNESS**

Informazioni per la riparazione e tabella cavi

CAV	CSA	COL	CCT	DESTN	Cavo precablato	Estrattore	Applicatore	Pinza spelafili	Manicotto termorestringente	ID	Giunzione
2	2.5D	R	885R	S/JOINT SJ1014	418-587-15	418-595	418-116A	418-117	418-104	418-113	418-108
3	0.5D	B	885R	S/JOINT SJ173	418-412	418-595	418-116A	418-117	418-104	418-112	418-107
8	4.0D	NU	21R	C2410R	418-411	418-593	418-116A	418-117	418-104	418-114	418-109
10	0.75D	PW	252R	C2725R	418-587-16	418-593	418-116A	418-117	418-104	418-112 418-114	418-107
10	1.5D	WR	798R	C3070R	418-410	418-593	418-116A	418-117	418-104	418-113	418-108
11	4.0D	NR	200R	C2996R	418-411	418-593	418-116A	418-117	418-104	418-114	418-109
12	2.5D	R	252R	S/JOINT SJ1207	418-410	418-593	418-116A	418-117	418-104	418-113	418-108
12	2.5D	R	1145R	C3070R	418-410	418-593	418-116A	418-117	418-104	418-113	418-108
12	2.5D	R	1147R	S/JOINT SJ141	418-410	418-593	418-116A	418-117	418-104	418-113	418-108
14	0.5D	LG	885R	S/JOINT SJ1947	418-412	418-595	418-116A	418-117	418-104	418-112	418-107
18	0.5D	B	252R	Co635R	418-587-16	418-593	418-116A	418-117	418-104	418-112 418-114	418-107
18	0.5D	B	1145R	Co658R	418-587-16	418-593	418-116A	418-117	418-104	418-112 418-114	418-107
18	0.5D	SP	1147R	Co660R	418-587-16	418-593	418-116A	418-117	418-104	418-112 418-114	418-107
										418-112	

65	0.5D	BY	419R	C2321R	418-587-16	418-593	418-116A	418-117	418-104	418-114	418-107
66	0.5D	R	419R	C2321R	418-587-16	418-593	418-116A	418-117	418-104	418-112 418-114	418-107
67	0.5D	N	109R	Co584R	418-587-16	418-593	418-116A	418-117	418-104	418-112 418-114	418-107
68	0.5D	LG	109R	S/JOINT SJ1947	418-587-16	418-593	418-116A	418-117	418-104	418-112 418-114	418-107
69	0.5D	B	200R	S/JOINT SJ171	418-587-16	418-593	418-116A	418-117	418-104	418-112 418-114	418-107
71	0.5D	RO	200R	C2244R	418-587-16	418-593	418-116A	418-117	418-104	418-112 418-114	418-107
72	0.5D	R	200R	Co584R	418-587-16	418-593	418-116A	418-117	418-104	418-112 418-114	418-107
73	1.0D	B	200R	C2926R	418-587-16	418-593	418-116A	418-117	418-104	418-112 418-114	418-107
75	0.75D	N	252R	S/JOINT SJ1013	418-587-16	418-593	418-116A	418-117	418-104	418-112 418-114	418-107
76	0.5D	B	252R	Co635R	418-587-16	418-593	418-116A	418-117	418-104	418-112 418-114	418-107
76	1.0D	NW	1140R	Co660R	418-587-16	418-593	418-116A	418-117	418-104	418-112 418-114	418-107
77	0.5D	SO	1148R	C3070R	418-587-16	418-593	418-116A	418-117	418-104	418-112 418-114	418-107
77	0.5D	SO	1098R	Co635R	418-587-16	418-593	418-116A	418-117	418-104	418-112 418-114	418-107
77	0.5D	Y	1149R	S/JOINT SJ142	418-587-16	418-593	418-116A	418-117	418-104	418-112 418-114	418-107
78	0.5D	Y	1098R	Co635R	418-587-16	418-593	418-116A	418-117	418-104	418-112 418-114	418-107

78	0.5D	Y	1148R	S/JOINT SJ1208	418-587-16	418-593	418-116A	418-117	418-104	418-112 418-114	418-107
78	0.5D	GN	1149R	Co660R	418-587-16	418-593	418-116A	418-117	418-104	418-112 418-114	418-107
80	2.5D	B	183R	S/JOINT SJ879	418-410	418-593	418-116A	418-117	418-104	418-113	418-108
81	0.5D	GR	183R	Co584R	418-587-16	418-593	418-116A	418-117	418-104	418-112 418-114	418-107
83	1.0D	B	200R	S/JOINT SJ173	418-412	418-595	418-116A	418-117	418-104	418-112	418-107
85	6.0D	PS	109R	S/JOINT SJ1000	418-419	-	418-116A	418-117	418-104	418-114	418-109
87	6.0D	PW	109R	Co570R	418-417	-	418-116A	418-117	418-104	-	-
91	4.0D	RU	1096R	C3842R	418-499	418-595	418-116A	418-117	418-105	418-114	418-109
92	2.5D	RLG	183R	Co828	418-410	418-593	418-116A	418-117	418-104	418-113	418-108
94	1.5D	NY	113R	Co570R	418-587-15	418-595	418-116A	418-117	418-104	418-113	418-108
95	0.5D	LG	572R	S/JOINT SJ1947	418-412	418-595	418-116A	418-117	418-104	418-112	418-107
98	2.5D	NR	419R	S/JOINT SJ1572	418-096	418-595	418-116A	418-117	418-104	418-113	418-108
106	0.75D	O	377R	C3058R	418-416	418-595	418-116A	418-117	418-104	418-112	418-107
107	0.75D	R	413R	Co506R	418-416	418-595	418-116A	418-117	418-104	418-112	418-107
108	2.5D	NG	413R	Co506R	418-096	418-595	418-116A	418-117	418-104	418-113	418-108
110	1.5D	UG	200R	Co570R	418-096	418-595	418-116A	418-117	418-104	418-113	418-108
113	4.0D	R	413R	Co506R	418-587-06	-	418-116A	418-117	418-104	418-114	418-109
114	4.0D	NP	200R	C2245R	418-587-06	-	418-116A	418-117	418-104	418-114	418-109
115	4.0D	PU	200R	C2410R	418-587-06	-	418-116A	418-117	418-104	418-114	418-109
116	4.0D	NU	200R	Co583R	418-587-06	-	418-116A	418-117	418-104	418-114	418-109
117	6.0D	NR	200R	Co583R	418-419	-	418-116A	418-117	418-104	418-114	418-109
118	0.5D	NO	200R	Co584R	418-412	418-595	418-116A	418-117	418-104	418-112	418-107

119	2.5D	WP	254R	S/JJOINT SJ1489	418-096	418-595	418-116A	418-117	418-104	418-113	418-108
119	4.0D	WP	252R	C2244R	418-413	-	418-116A	418-117	418-104	418-114	418-109
120	1.0D	NR	419R	C2320R	418-416	418-595	418-116A	418-117	418-104	418-112	418-107
121	0.75D	UN	1145R	S/JJOINT SJ1868	418-416	418-595	418-116A	418-117	418-104	418-112	418-107
121	0.75D	WG	252R	S/JJOINT SJ1450	418-416	418-595	418-116A	418-117	418-104	418-112	418-107
121	1.5D	WG	1147R	S/JJOINT SJ1868	418-096	418-595	418-116A	418-117	418-104	418-113	418-108
122	0.75D	PO	405R	C2025	418-416	418-595	418-116A	418-117	418-104	418-112	418-107
124	2.5D	WR	252R	C3424R	418-096	418-595	418-116A	418-117	418-104	418-113	418-108
124	1.0D	NU	1140R	C2293	418-416	418-595	418-116A	418-117	418-104	418-112	418-107
125	1.0D	G	252R	C2725R	418-416	418-595	418-116A	418-117	418-104	418-112	418-107
125	1.0D	U	254R	S/JJOINT SJ1933	418-416	418-595	418-116A	418-117	418-104	418-112	418-107
126	0.5D	PW	200R	S/JJOINT SJ104	418-521	418-595	418-116A	418-117	418-104	418-112	418-107
127	1.5D	NK	252R	C3426R	418-096	418-595	418-116A	418-117	418-104	418-113	418-108
127	1.5D	RU	1145R	S/JJOINT SJ1511	418-096	418-595	418-116A	418-117	418-104	418-113	418-108
127	0.75D	PG	1147R	S/JJOINT SJ1511	418-416	418-595	418-116A	418-117	418-104	418-112	418-107
141	1.5D	B	200R	C0004	418-587-15	418-595	418-116A	418-117	418-104	418-113	418-108
148	1.5D	NY	113R	C0570R	418-096	418-595	418-116A	418-117	418-104	418-113	418-108
151	2.5D	R	252R	S/JJOINT SJ1207	418-096	418-595	418-116A	418-117	418-104	418-113	418-108
151	2.5D	R	1147R	S/JJOINT SJ141	418-096	418-595	418-116A	418-117	418-104	418-113	418-108
165	0.5D	NG	200R	C2240R	418-412	418-595	418-116A	418-117	418-104	418-112	418-107
166	0.75D	NK	252R	S/JJOINT SJ1941	418-416	418-595	418-116A	418-117	418-104	418-112	418-107
166	0.5D	PN	97R	C2410R	418-521	418-595	418-116A	418-117	418-104	418-112	418-107
167	2.5D	G	1145R	S/JJOINT SJ1946	418-096	418-595	418-116A	418-117	418-104	418-113	418-108
167	2.5D	RW	252R	C2725R	418-096	418-595	418-116A	418-117	418-104	418-113	418-108

168	1.5D	BN	1145R	S/JOINT SJ630	418-096	418-595	418-116A	418-117	418-104	418-113	418-108
168	1.0D	N	252R	S/JOINT SJ1013	418-416	418-595	418-116A	418-117	418-104	418-112	418-107
168	1.5D	PS	1147R	S/JOINT SJ1118	418-096	418-595	418-116A	418-117	418-104	418-113	418-108
170	0.75D	P	254R	S/JOINT SJ1866	418-416	418-595	418-116A	418-117	418-104	418-112	418-107
171	1.5D	NY	113R	S/JOINT SJ170	418-096	418-595	418-116A	418-117	418-104	418-113	418-108
172	2.5D	WG	252R	C3424R	418-096	418-595	418-116A	418-117	418-104	418-113	418-108
173	0.5D	GN	200R	C2244R	418-521	418-595	418-116A	418-117	418-104	418-112	418-107
174	0.5D	WG	252R	C0635R	418-521	418-595	418-116A	418-117	418-104	418-112	418-107
174	0.5D	R	1147R	C0660R	418-521	418-595	418-116A	418-117	418-104	418-112	418-107
178	2.5D	PU	419R	C2321R	418-096	418-595	418-116A	418-117	418-104	418-113	418-108
179	4.0D	WY	1140R	C2244R	418-413	-	418-116A	418-117	418-104	418-114	418-109
180	1.5D	PY	200R	S/JOINT SJ1062	418-096	418-595	418-116A	418-117	418-104	418-113	418-108
181	6.0D	GY	200R	C2293	418-419	-	418-116A	418-117	418-104	418-114	418-109
185	4.0D	NG	200R	C0583R	418-587-06	-	418-116A	418-117	418-104	418-114	418-109
186	6.0D	NS	200R	C0583R	418-419	-	418-116A	418-117	418-104	418-114	418-109
189	6.0D	PW	109R	C0570R	418-417	-	418-116A	418-117	418-104	-	-
191	6.0D	YR	254R	C0190	-	-	-	-	-	-	-
192	6.0D	R	200R	C2960R	-	-	-	-	-	-	-

[Cliccare qui per stampare](#)

Connettore: **C0583R**

ALLOGGIAMENTO DEL CONNETTORE RIPARABILE

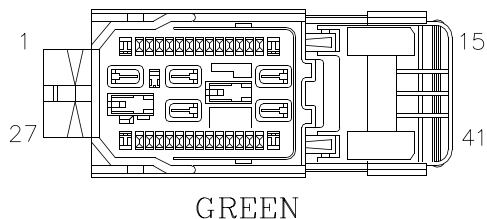

Descrizione: **Scatola portafusibili-Abitacolo**

Ubicazione: **Dietro il lato passeggero della plancia**

Qualifier:

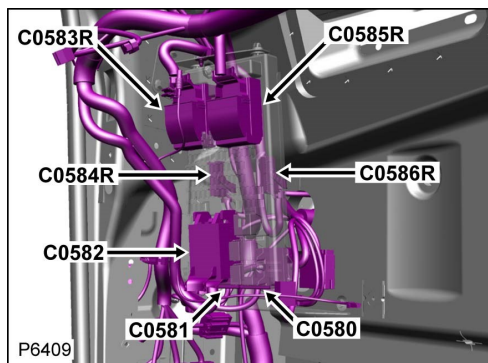

Numero parte progettazione: **3M5T-14489-ZRC**

Numero parte ricambio: **YPC801110**

Colore: **GREEN**

Cavità: **41WY**

Cablaggio: **ENGINE COMPARTMENT HARNESS**

Informazioni per la riparazione e tabella cavi

CAV	CSA	COL	CCT	DESTN	Cavo precablato	Estrattore	Applicatore	Pinza spelafili	Manicotto termorestringente	ID	Giunzione
2	1.5D	OB	200R	C0008	418-248	418-665	418-116A	418-117	418-104	418-112	418-107
3	1.5D	BO	200R	C0008	418-248	418-665	418-116A	418-117	418-104	418-112	418-107
4	0.5D	GO	200R	C0009	418-411-13	418-595	418-116A	418-117	418-104	418-112	418-107
8	0.5D	WR	405R	C2025	418-411-13	418-595	418-116A	418-117	418-104	418-112	418-107
10	0.75D	LG	413R	S/JOINT SJ1109	-	-	-	-	-	-	-
11	0.5D	RB	200R	C2410R	418-411-13	418-595	418-116A	418-117	418-104	418-112	418-107
12	0.5D	RO	200R	C2410R	418-411-13	418-595	418-116A	418-117	418-104	418-112	418-107
13	0.75D	LGW	200R	C2244R	-	-	-	-	-	-	-
16	4.0D	NG	200R	C0570R	418-358	418-593	418-116A	418-117	418-105	418-114	418-109
20	4.0D	NU	200R	C0570R	-	-	-	-	-	-	-
21	6.0D	NS	200R	C0570R	-	-	-	-	-	-	-
22	6.0D	NR	200R	C0570R	-	-	-	-	-	-	-
24	0.5D	B	200R	C0666R	418-411-13	418-595	418-116A	418-117	418-104	418-112	418-107
27	1.5D	UP	93R	C2277	418-411-17	418-595	418-116A	418-117	418-104	418-113	418-108
28	0.5D	RB	200R	C0009	418-411-13	418-595	418-116A	418-117	418-104	418-112	418-107
29	1.5D	UO	200R	C0011	418-248	418-665	418-116A	418-117	418-104	418-112	418-107

30	0.5D	R	200R	C0011	418-411-13	418-595	418-116A	418-117	418-104	418-112	418-107
31	1.0D	OB	200R	C0520R	-	-	-	-	-	-	-
32	0.5D	GR	200R	C0009	418-411-13	418-595	418-116A	418-117	418-104	418-112	418-107
34	1.0D	RO	200R	C0011	-	-	-	-	-	-	-
37	1.5D	GW	200R	C0011	418-248	418-665	418-116A	418-117	418-104	418-112	418-107
38	1.5D	UK	200R	C0009	418-248	418-665	418-116A	418-117	418-104	418-112	418-107
39	0.5D	RO	404R	C0011	418-411-13	418-595	418-116A	418-117	418-104	418-112	418-107
40	0.5D	RB	404R	C0009	418-411-13	418-595	418-116A	418-117	418-104	418-112	418-107

Connettore: **C0583R**

ALLOGGIAMENTO DEL CONNETTORE RIPARABILE

Descrizione: **Scatola portafusibili-Abitacolo**

Ubicazione: **Dietro il lato passeggero della plancia**

Qualifier:

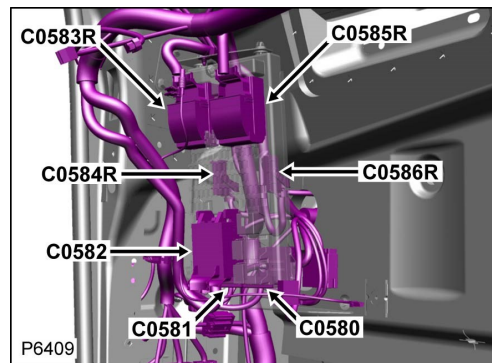

Numero parte progettazione: **3M5T-14489-ZRC**

Numero parte ricambio: **YPC801110**

Colore: **GREEN**

Cavità: **41WY**

Cablaggio: **ENGINE COMPARTMENT HARNESS**

Informazioni per la riparazione e tabella cavi

CAV	CSA	COL	CCT	DESTN	Cavo precablato	Estrattore	Applicatore	Pinza spelafili	Manicotto termorestringente	ID	Giunzione
2	1.5D	OB	200R	C0008	418-248	418-665	418-116A	418-117	418-104	418-112	418-107
3	1.5D	BO	200R	C0008	418-248	418-665	418-116A	418-117	418-104	418-112	418-107
4	0.5D	GO	200R	C0009	418-411-13	418-595	418-116A	418-117	418-104	418-112	418-107
8	0.5D	WR	405R	C2025	418-411-13	418-595	418-116A	418-117	418-104	418-112	418-107
10	0.75D	LG	413R	S/JOINT SJ1109	-	-	-	-	-	-	-
11	0.5D	RB	200R	C2410R	418-411-13	418-595	418-116A	418-117	418-104	418-112	418-107
12	0.5D	RO	200R	C2410R	418-411-13	418-595	418-116A	418-117	418-104	418-112	418-107
13	0.75D	LGW	200R	C2244R	-	-	-	-	-	-	-

16	4.0D	NG	200R	C0570R	418-358	418-593	418-116A	418-117	418-105	418-114	418-109
20	4.0D	NU	200R	C0570R	-	-	-	-	-	-	-
21	6.0D	NS	200R	C0570R	-	-	-	-	-	-	-
22	6.0D	NR	200R	C0570R	-	-	-	-	-	-	-
24	0.5D	B	200R	C0666R	418-411-13	418-595	418-116A	418-117	418-104	418-112	418-107
27	1.5D	UP	93R	C2277	418-411-17	418-595	418-116A	418-117	418-104	418-113	418-108
28	0.5D	RB	200R	C0009	418-411-13	418-595	418-116A	418-117	418-104	418-112	418-107
29	1.5D	UO	200R	C0011	418-248	418-665	418-116A	418-117	418-104	418-112	418-107
30	0.5D	R	200R	C0011	418-411-13	418-595	418-116A	418-117	418-104	418-112	418-107
31	1.0D	OB	200R	C0520R	-	-	-	-	-	-	-
32	0.5D	GR	200R	C0009	418-411-13	418-595	418-116A	418-117	418-104	418-112	418-107
34	1.0D	RO	200R	C0011	-	-	-	-	-	-	-
37	1.5D	GW	200R	C0011	418-248	418-665	418-116A	418-117	418-104	418-112	418-107
38	1.5D	UK	200R	C0009	418-248	418-665	418-116A	418-117	418-104	418-112	418-107
39	0.5D	RO	404R	C0011	418-411-13	418-595	418-116A	418-117	418-104	418-112	418-107
40	0.5D	RB	404R	C0009	418-411-13	418-595	418-116A	418-117	418-104	418-112	418-107