



# TECHNICAL BULLETIN

No: LA-501-012

Issue: 2

Date: 14 Mar 2006

CIRCULATE: TO

Service Mgr  
X

Warranty  
X

Workshop  
X

Body Shop  
X

Parts  
X

**SECTION:** 501-01

## Passenger Compartment Water Ingress

### AFFECTED VEHICLE RANGE:

Land Rover LR3 (LA)

VIN: 5A000360 and up

### CONDITION SUMMARY:



**NOTE:** Issue 2 changes are highlighted in gray.

### POSSIBLE CAUSES AND RESOLUTION OF WATER INGRESS

This informational bulletin provides technicians with guidance for identification of possible water ingress causes when water enters the passenger compartment of LR3 vehicles. If a customer complains of water ingress, locate the point of origin and take the appropriate corrective action.

Symptom	Potential Root Cause
Water Ingress through headliner in proximity of roof opening panel.	Sealed end valve of the roof opening panel drain tubes. This may affect any one of the four roof opening panel drain tubes on the vehicle.
	Roof opening panel alignment or loose roof opening panel Torx screws.
	Badly routed, kinked or twisted roof opening panel drain tubes.
	Incorrect lateral position of roof opening panel lateral alignment, causing the seal to leak. Note: This root cause will result in substantial water ingress.
Water Ingress through headliner in proximity of roof opening panel, predominantly front right-hand side of roof opening panel although depending upon inclination of vehicle, or acceleration/deceleration, ingress may be evident at other points around the roof opening panel.	Foam sound-deadening pad in right-hand side fender air intake blocking the sunroof panel drain tube.
Water ingress to foot well (driver or passenger side) or under second row seats (driver or passenger side).	Roof opening panel drain tube end not routed through the fender or wheel arch, or drain tube end pinched or clogged with debris.
Water ingress to passenger side foot well, water dripping from the glove compartment area. Note: There may be a delay of days between the vehicle being subjected to water and the complaint of water ingress arising due to the time taken for the water to soak through the pollen filter.	Plenum chamber panel not securely clipped, allowing water to pass through the air inlet, positioned on the passenger side of the vehicle, and collecting in the pollen filter.
Illumination of miscellaneous warning lamps and/or water in foot well.	Refer to NAS Technical Bulletin LA501-006 to address A-Pillar water leak.

**NOTE:** The information in Technical Bulletins is intended for use by trained, professional technicians with the knowledge, tools, and equipment required to do the job properly and safely. It informs these technicians of conditions that may occur on some vehicles, or provides information that could assist in proper vehicle service. The procedures should not be performed by "do-it-yourselfers."

If you are not a Retailer, do not assume that a condition described affects your vehicle. Contact an authorized Land Rover service facility to determine whether the bulletin applies to a specific vehicle.



**PARTS:**

Troubleshooting and diagnosis only.

**WARRANTY:**

*This procedure is issued for information and guidance only. Only those procedures justified by a customer complaint are allowed to be claimed, and will be subject to warranty audit.*

*Normal warranty policy and procedures apply.*

---

## REPAIR PROCEDURE

### TEST SUNROOF DRAINS

1. Perform the following test to determine if the sunroof drain tubes are functioning normally or are potentially the water ingress source.



**NOTE:** The restricted access caused by the roof opening panel glass may require the vehicle to be inclined rearward slightly to pass water down the rear drain holes.

- Place the vehicle on dry level ground.
- Fully open the sunroof panel to gain access to the water trap.
- Carefully pour water into the water traps, one corner at a time so that the water drains into the drain hole and drain hose. (Figures 1 and Figure 2)
- Confirm that water has pooled on the ground at all four drain points under the A-pillar and C-pillars on both sides of the vehicle. (Figures 1 and 2)

Figure 1 RH Front Side Shown

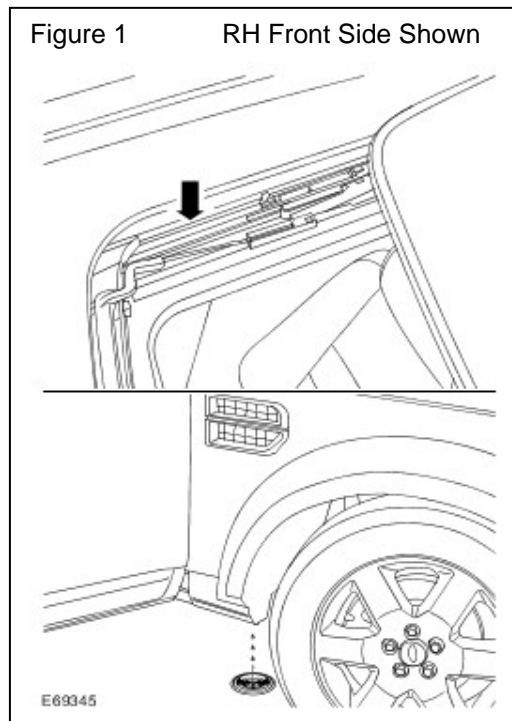
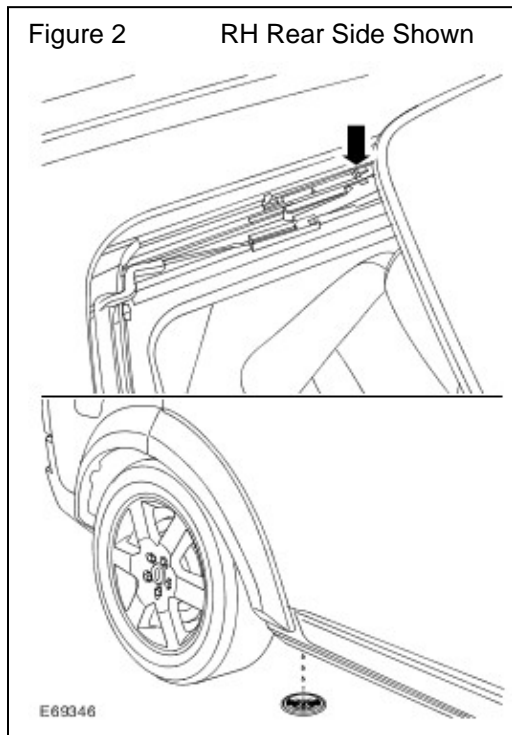

Figure 2 RH Rear Side Shown



## RIGHT FRONT DRAIN CORRECTION PROCEDURE

**NOTE:** This procedure should be followed if there is no water found pooling on the ground below the right-hand side A-Pillar during testing.

**CAUTION:** Care should be taken when removing the fender air intake grill to prevent damage to the retaining clips.

1. Remove the fender air intake grill by first pulling up to release the two lower clips, then pulling down and outward to release the two upper clips. (Figure 3)
2. Remove the air duct and foam insulation pad to gain access to the roof opening panel drain tube. (Figure 3)
3. Verify that the drain tube is protruding through the hole in the body. (Figure 4)

**NOTE:** GTR lookup sequence is as follows:  
GTR Home > NAS > Service Information/ LA LR3/2006> Workshop Manuals > Discovery 3/LR3 2005 Workshop Manual > Bookmark "Body and Paint/Body and Paint/501-05 Interior Trim and Ornamentation" > Link "Cowl Side Trim Panel (76.13.27)"

4. If the tube is not protruding through the hole in the body perform the following steps to correctly position the roof opening panel drain tube:
  - Refer to GTR Workshop Manual Section 76.13.27 and remove the cowl side trim panel to gain access to the roof opening panel drain tube.
  - Connect and secure the drain tube through the hole
  - Verify the valve of the roof opening panel drain tube can be fully opened. (Figure 5)
  - If the valve can not be opened, cut as required to permit full opening. (Figure 5)
  - Install cowl side trim panel

**NOTE:** If both the routing of the roof opening panel drain tube is correct and the valve of the roof opening panel drain tube cannot be faulted, the foam insulation pad may be the cause. The foam sound-deadening pad may have been installed in such a way as to block the roof opening panel drain tube.

5. Remove and then install the foam sound-deadening pad, taking care to ensure that the roof opening panel drain tube valve locates in the indent in the foam insulation pad to avoid crimping the tube.
6. Confirm free-flow of water by repeating "Test Sunroof Drains" procedure for the right front drain.
7. If satisfactory test is completed install the duct and fender air intake grill.
8. If satisfactory test is NOT completed, blow out the drain tube with compressed air and test again.

Figure 3

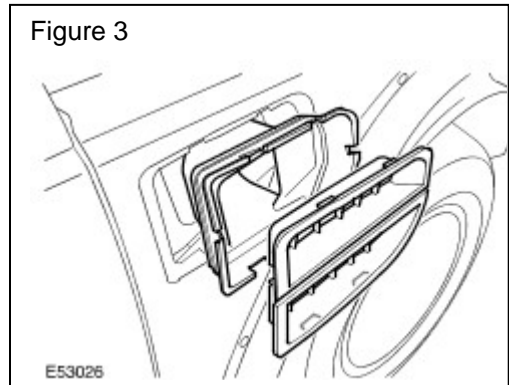
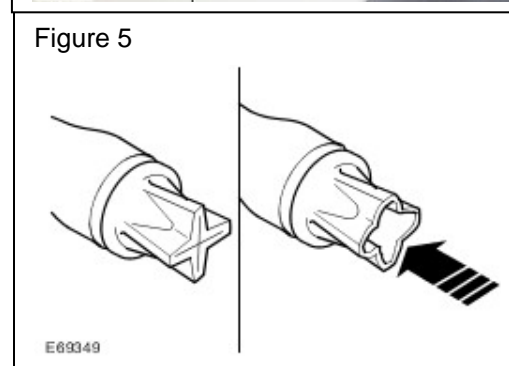

Figure 4

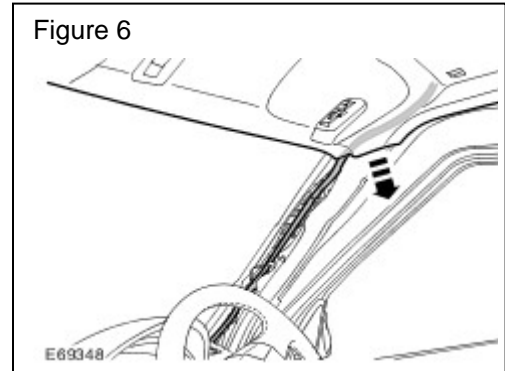

Figure 5



9. If satisfactory test is still NOT completed, refer to GTR Workshop Manual Interior Trim and Ornamentation Section 76.64.15 and remove the headliner to gain access to the drain tube. (Figure 6)
10. Inspect for misrouting or kinking of the roof opening panel drain tube paying particular attention to :
  - Collapsed elbow joints
  - Pinched tube
  - Inclined routing
11. Repair drain tube routing as necessary and confirm free-flow of water by repeating "Test Sunroof Drains" procedure for the right front drain.
12. If satisfactory test is completed, install the headliner.
13. Install the duct and fender air intake grill.

Figure 6



## LEFT FRONT DRAIN CORRECTION PROCEDURE

 **NOTE:** This procedure should be followed if there is no water found pooling on the ground below the left-hand side A-Pillar during testing.

1. Turn the wheels to the fully left lock position.

 **NOTE:** GTR lookup sequence is as follows:  
**GTR Home > NAS > Service Information/ LA LR3/2006> Workshop Manuals > Discovery 3/LR3 2005 Workshop Manual > Bookmark "Body and Paint/Body and Paint/501-08 Exterior Trim and Ornamentation" > Link "Fender moulding (76.43.54)"**

2. Refer to GTR Workshop Manual Section 76.43.54 and partially release the left-hand front fender molding.
3. Partially release the left-hand front wheel arch lining, to gain access to the roof opening panel drain tube. (Figure 7)
4. Verify that the drain tube is protruding through the hole in the body.
5. If the drain tube is not protruding perform the following:

 **NOTE:** GTR lookup sequence is as follows:  
**GTR Home > NAS > Service Information/ LA LR3/2006> Workshop Manuals > Discovery 3/LR3 Workshop Manual > Bookmark "Electrical Distribution/418-00" > Link "Central Junction Box (CJB) (86.70.56)"**

- Refer to GTR Workshop Manual Section 86.70.56 and remove the CJB to gain access to the sunroof panel drain tube.
  - Connect and secure the drain tube through the hole in the body.
  - Check the valve of the roof opening panel drain tube can be fully opened. (Figure 5)
  - If the valve can not be opened, cut as required to permit full opening. (Figure 5)
6. Confirm free-flow of water by repeating "Test Sunroof Drains" procedure for the left front drain.
  7. If the concern has not been corrected, blow out drain tube with compressed air and retest.

Figure 7

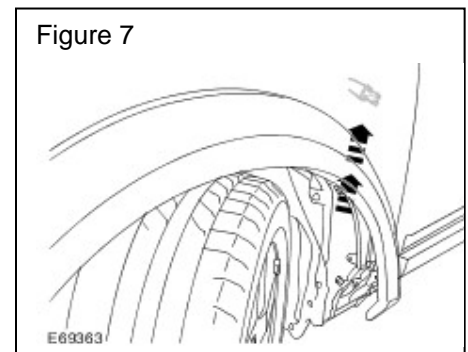



8. If the concern has still NOT been corrected, refer to GTR Workshop Manual Section 76.64.15 and remove the headliner to gain access to the drain tube. (Figure 8)
9. Inspect for misrouting or kinking of the roof opening panel drain tube, paying particular attention to:
  - Collapsed elbow joints
  - Pinched tube
  - Inclined routing
10. Repair drain tube routing as necessary and retest.
11. If satisfactory test is completed install the headliner.
12. Install the CJB.
13. When testing is satisfactorily completed, refer to GTR Section 76.43.54 and install the left-hand front wheel arch lining and left-hand front wheel arch molding.

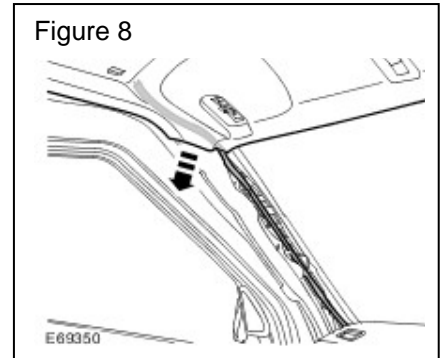

## RIGHT REAR DRAIN CORRECTION PROCEDURE

**NOTE:** This procedure should be followed if there is no water is found pooling on the ground below the right-hand side C-Pillar during testing.

**CAUTION:** The fender panel rubber lip moulding is not to be displaced from installed position. Care must be taken when pulling the fender splash shield down to gain access to the drain tube ends.

1. Open the right-hand side rear door.
2. Carefully pull the fender splash shield down to access roof opening panel drain tube. (Figure 9)
3. Verify that the roof opening panel drain tube is protruding through the hole in the body.
4. If the tube is not protruding perform the following:
  - Refer to GTR Workshop Manual Interior Trim and Ornamentation Section 76.13.34 and release the right-hand side C-pillar lower trim panel to gain access to the roof opening panel drain tube.
  - Connect and secure the drain tube through the hole in the body.
5. Check that the valve of the drain tube can be fully opened. (figure 5)
6. If the valve can not be opened, cut as required to permit full opening. (Figure 5)
7. Confirm free-flow of water by repeating "Test Sunroof Drains" procedure for the right rear drain.
8. If the concern has not been corrected, blow out drain tube with compressed air and retest.
9. If the concern has still NOT been corrected refer to GTR Section 76.64.15 and remove the headliner to gain access to the drain tube. (Figure 10)
10. Inspect for misrouting or kinking of the roof opening panel drain tube, paying particular attention to:
  - Collapsed elbow joints
  - Pinched tube
  - Inclined routing

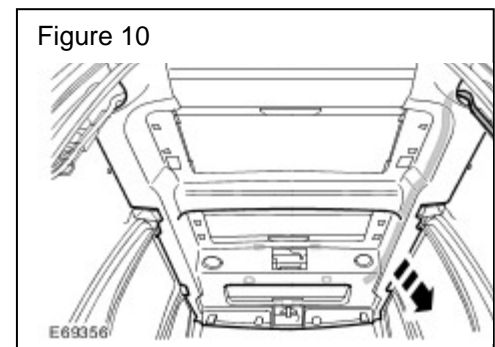
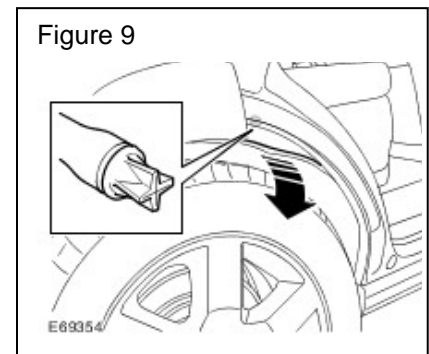

11. Repair drain tube routing as necessary and retest.
12. If satisfactory test is completed, install the headliner.
13. Install the C-pillar lower trim panel.
14. Install the fender splash shield pulled away to access roof opening panel drain tube.

## LEFT REAR DRAIN CORRECTION PROCEDURE

**NOTE:** This procedure should be followed if there is no water found pooling on the ground below the left-hand side C-Pillar during testing.

**CAUTION:** The fender panel rubber lip moulding is not to be displaced from installed position. Care must be taken when pulling the fender splash shield down to gain access to the drain tube ends.

1. Open the left-hand side rear door.
2. Carefully pull the fender splash shield down to access the roof opening panel drain tube. (Figure 11)
3. Verify that the drain tube is protruding through the hole in the body.
4. If the tube is not protruding, perform the following:
  - Refer to GTR Workshop Manual Section 76.13.34 and release the left-hand side C-pillar lower trim panel to gain access to the roof opening panel drain tube.
  - Connect and secure the drain tube through the hole in the body.
5. Check that the valve of the drain tube can be fully opened.
6. If the valve can not be opened, cut as required to permit full opening. (Figure 5)
7. Confirm free-flow of water by repeating "Test Sunroof Drains" procedure for the left rear drain.
8. If the concern has not been corrected, blow out drain tube with compressed air and retest.
9. If the concern has still NOT been corrected refer to GTR Section 76.64.15 and remove the headliner to gain access to the drain tube. (Figure 12)
10. Inspect for misrouting or kinking of the roof opening panel drain tube, paying particular attention to:
  - Collapsed elbow joints
  - Pinched tube
  - Inclined routing
11. Repair drain tube routing as necessary and retest.
12. If satisfactory test completed, install the headliner.
13. Install the C-pillar lower trim panel.
14. Install the fender splash shield pulled away to access roof opening panel drain tube.

Figure 11

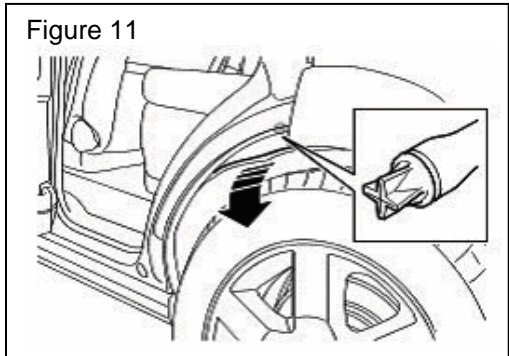
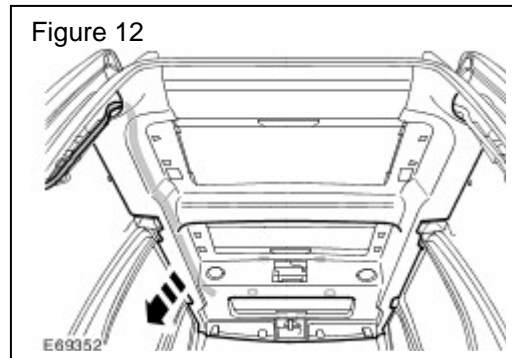

Figure 12



## ROOF OPENING PANEL ALIGNMENT OR LOOSE TORX SCREWS AS POTENTIAL LEAK SOURCE



**NOTE:** When all of the drain tubes are confirmed as functioning correctly the Torx screws securing the glass roof panel can be tested as a leak source.

1. Open the roof opening panel blind, leaving the roof opening panel closed.
2. Verify that the glass is centered in its opening.
3. Verify that the front edge is set flush or up to 1.0 mm (0.040 in) below the roof line.
4. Verify that the rear edge is set flush or up to 1.0 mm (0.040 in) higher than the roof line.
5. From inside the vehicle, verify that all six (6) Torx screws securing the roof opening panel are correctly positioned and tightened to **6 Nm (4.5 lbf-ft)**. (Figure 13)
6. If the roof opening panel is not set within the specified conditions or if any Torx screw is loose, align the roof opening panel as follows:
  - Loosen the six (6) roof opening panel Torx screws
  - Align the roof opening panel so it is centered in all directions to the exterior roof panel opening
  - Verify that the exterior front and rear edges are set within the specified conditions
  - Tighten the six (6) roof opening panel Torx screws to **6 Nm (4.5 lbf-ft)**.
7. Verify proper operation of the roof opening panel.
8. Close the roof opening panel blind.

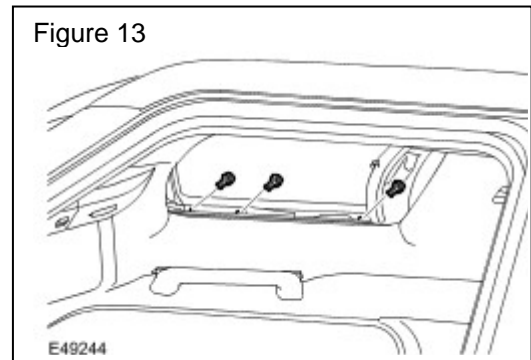

## WATER INGRESS TO GLOVE COMPARTMENT OR PASSENGER FOOT WELL



**NOTE:** If the previous steps have been carried out and both the roof opening panel drain tubes and the alignment/fasteners of the roof opening panel are correctly assembled, without the need for corrective action, this final check may reveal a footwell leak source.

1. Confirm that the plenum chamber panel is securely clipped as follows:
  - Inspect and verify that there is no visible gapping.
  - Gently but firmly applying pressure across the panel to confirm it is seated.
  - Listen for a click sound, which indicates that a clip has engaged (if not already engaged).

## A-PILLAR WATER LEAK TO FOOT WELL

1. Refer to NAS Technical Bulletin LA501-006 and follow inspection and repair procedure for A-pillar trim clip replacement and sealing.