

Jacking

General



WARNING: The following instructions must be adhered to before raising the vehicle off the ground:

- Position vehicle on a solid, level surface.
- Apply the parking brake.
- Select 'P' - PARK on automatic transmission selector or 1st gear on manual transmission and 'H' High on transfer case.



WARNING: If the drive shaft(s) are to be disconnected, it will be necessary to raise all four wheels off the ground in order that the shaft(s) can be rotated. **DO NOT** use the customer jack and ensure that the vehicle is adequately supported on axle stands. With the vehicle raised, it will be necessary to release the park brake and select Neutral - 'N' in the main transmission to enable the drive shaft(s) to be rotated



CAUTION: To avoid damage to the underbody components of the vehicle, the following instructions must be adhered to:



CAUTION: Do not position jacks or axle stands under the following components:

- Body structure other than any approved jacking or lifting points
- Bumpers

- Fuel lines

- Fuel tank

- Brake lines

- Front or rear suspension arms

- Steering linkage

- Transfer case

- Front or rear differential units

- Transmission

- Engine oil pan - See note below

NOTE:

For certain repair operations, it may be necessary to support the engine under the oil pan. In this case, a block of hardwood or a rubber pad must be positioned on the jack lifting pad to protect the oil pan.

Vehicle jack

The jack provided with the vehicle is only intended for use in an emergency such as changing a tire. DO NOT use the jack for any other purpose. Refer to the Owner's Handbook for the vehicle jack location points and jacking procedures.



WARNING: Never work under a vehicle supported solely by the vehicle jack.

Hydraulic jack

A hydraulic jack with a minimum lifting capacity of 1500 kg, (3,300 lbs) must be used.



WARNING: Do not commence work on the underside of the vehicle until suitable axle stands have been placed in the correct position.



WARNING: Always chock the wheels when jacking. The parking brake may be ineffective when the wheel(s) are off the ground.

Raising and Supporting the Vehicle

To assist in raising the vehicle, jacking points are provided as shown in the following illustrations.

Raising the Front of the Vehicle

Apply the parking brake.

Select 'P' - PARK on automatic transmission selector.



WARNING: Always chock the rear wheels when jacking the front of the vehicle.

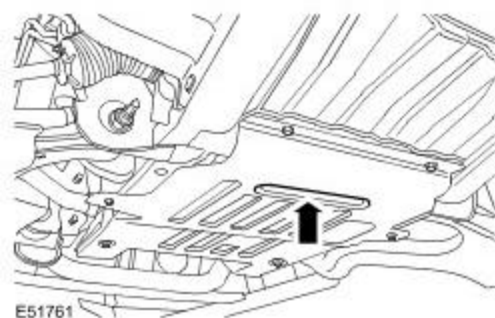

Position the lifting pad of the hydraulic jack in the centre of the recess in the engine undershield.

NOTE:

If the engine undershield has been removed, position the jack lifting pad in the centre of the front cross beam.

With the vehicle raised to the desired height, position axle stands at positions shown.

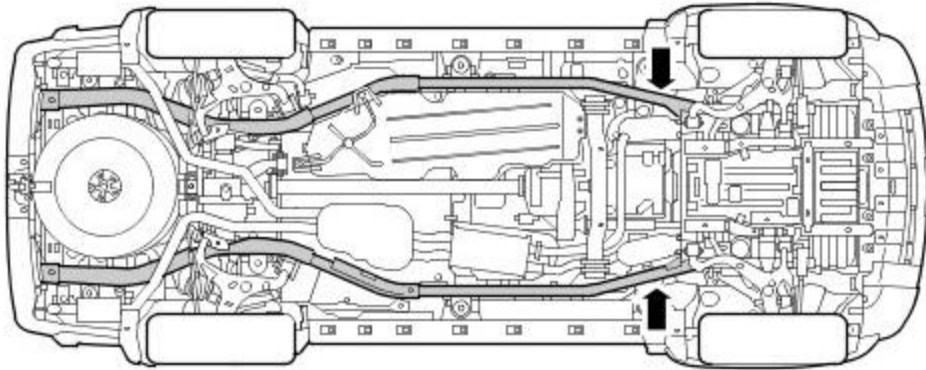

E53784



CAUTION: Position suitable material between axle stands and longitudinal members to prevent damage to the longitudinal members.

Carefully lower jack until vehicle rests on axle stands.



WARNING: Before commencing work on the underside of the vehicle, ensure that axle stands are correctly positioned and vehicle is securely supported.

Reverse procedure when removing vehicle from stands.

Raising the Rear of the Vehicle

Select 'P' - PARK on automatic transmission selector.



WARNING: Always chock the front wheels when jacking the rear of the vehicle.

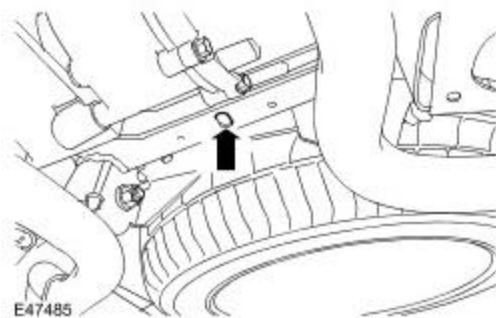

E47485

Position the lifting pad of the hydraulic jack under the centre of the rear cross member as shown.



CAUTION: Take care that the lifting pad of the jack is of a suitable size to avoid damaging the heat shield. It is not advisable to use a spacer block between the lifting pad and the rear cross member as this may result in some vehicle instability.

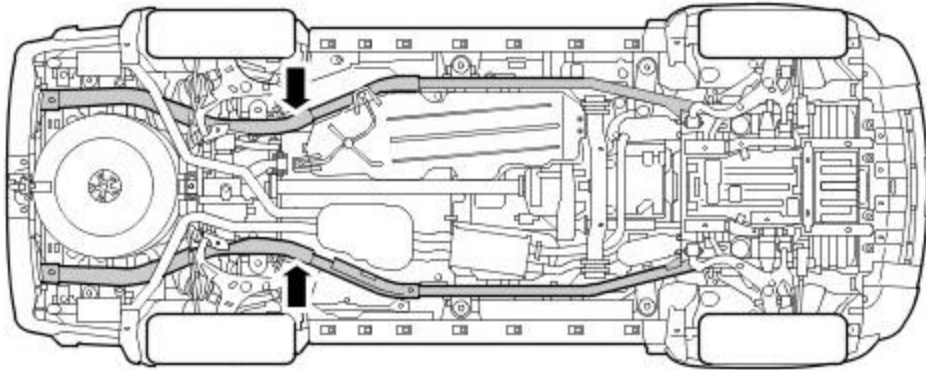

E47486

With vehicle raised to desired height, position axle stands at positions shown.



CAUTION: Position suitable material between axle stands and longitudinal members to prevent damage to the longitudinal members.

Carefully lower jack until vehicle rests on axle stands.



WARNING: Before commencing work on underside of vehicle, ensure that axle stands are correctly positioned and vehicle is securely supported.

Reverse procedure when removing vehicle from stands.

Raising Vehicle - One Wheel/side

Apply the parking brake.

Select 'P' - PARK on automatic transmission selector.



WARNING: Always chock the wheels which are not to be raised.

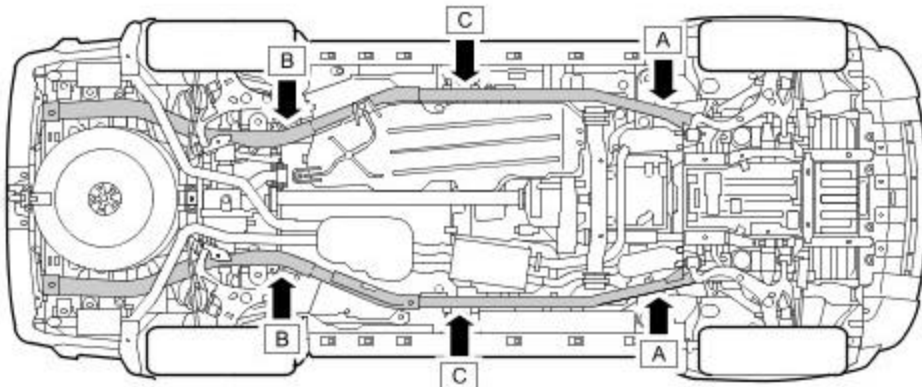

E47487

- One front wheel - position lifting pad of hydraulic jack beneath longitudinal member on the side to be raised at

- Point 'A'
- One rear wheel - position lifting pad of jack beneath longitudinal member on the side to be raised at Point 'B'
 - Front and rear wheels - ONE SIDE - position lifting pad of jack beneath longitudinal member on the side to be raised at Point 'C'

NOTE:

Point 'C' is in line with number 3 body mounting.

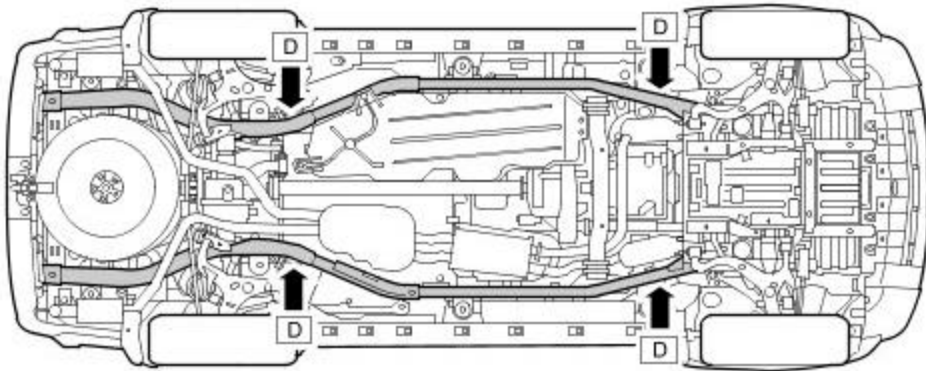

E47488

With vehicle at desired height, position axle stand(s) beneath longitudinal members and adjacent to the lifting pad of the jack at appropriate point(s) D.



CAUTION: Position suitable material between axle stands and longitudinal members to prevent damage to the longitudinal members.

Carefully lower jack until vehicle rests on axle stands.



WARNING: Before commencing work on underside of vehicle, ensure that axle stands are correctly positioned and vehicle is securely supported.

Reverse procedure when removing vehicle from stands.