

TECHNICAL BULLETIN
LTB00420v2
03 OCT 2012



© Jaguar Land Rover Limited
All rights reserved.

This reissue replaces all previous versions. Please destroy all previous versions. Only refer to the electronic version of this Technical Bulletin in TOPIx.
This bulletin supersedes TSB LTB00420/2011 dated 25 NOV 2011, which should either be destroyed or clearly marked to show it is no longer valid (e.g. with a line across the page). Only refer to the electronic version of this Technical Bulletin in TOPIx.

SECTION: 204-05

Suspension Compressor Replacement

AFFECTED VEHICLE RANGE:

Discovery 3 / LR3 (LA)	Model Year:	2005-2009
	VIN:	5A000360-9A513325
Discovery 4 / LR4 (LA)	Model Year:	2010-2012
	VIN:	AA513326-CA638964
Range Rover Sport (LS)	Model Year:	2005-2013
	VIN:	5A900302-DA768550

MARKETS:

All

CONDITION SUMMARY:

Situation:

A customer may report a concern that the air suspension warning lamp is illuminated and the suspension will not rise.

This version has been issued to add pre 10MY vehicles.

Manufacturing have previously used two different types of air suspension compressors. See Below for applicable VIN Ranges. If the Hitachi or old-design AMK air suspension compressor requires replacement, then a new-design AMK air suspension compressor can be installed.

Hitachi air suspension compressor fitted from VIN:

Discovery 3/LR3 - 5A000360 to 9A513325

Range Rover Sport - 5A900302 to 9A215622

Hitachi or old-design AMK air suspension compressor fitted from VIN:



NOTE: Some vehicles may have been previously repaired using the old-design AMK air suspension compressor.

Discovery 4/LR4 - AA513326 to CA638964

Range Rover Sport - AA215623 to DA768550

Cause: The air suspension compressor. **Suggested Customer Concern Code C50.**



NOTE: The Fault Code C1A20-64 may also be displayed.

Action: Should a customer express concern, follow the Service Instruction outlined below.

PARTS:

LR044360 AMK Compressor Replacement Kit Quantity: 1

WARRANTY:

NOTE: Repair procedures are under constant review, and therefore times are subject to change; those quoted here must be taken as guidance only. Always refer to TOPIx to obtain the latest repair time.

NOTE: DDW requires the use of causal part numbers. Labor only claims must show the causal part number with a quantity of zero.

DESCRIPTION	SRO	TIME	CONDITION CODE	CAUSAL PART
Replace the Hitachi compressor with the AMK compressor	60.50.89/58	0.6 hours	42	LR023964 Hitachi LR032902 AMK

NOTE: Normal Warranty policies and procedures apply.

SERVICE INSTRUCTION:

NOTE: Some variation in the illustrations may occur, but the essential information is always correct.

1. **NOTE:** Hitachi compressor (number 1).

NOTE: Old-design AMK air suspension compressor (number 2).

NOTE: New-design AMK air suspension compressor (number 3).

NOTE: Note that there is a subtle difference between the 2 AMK air suspension compressors.

Identify the air suspension compressor installed on the vehicle.

1. If a Hitachi air suspension compressor is installed, carry out steps 2 to 19 and 38 to 44.
2. If an old-design AMK air suspension compressor is installed, carry out steps 20 to 44.

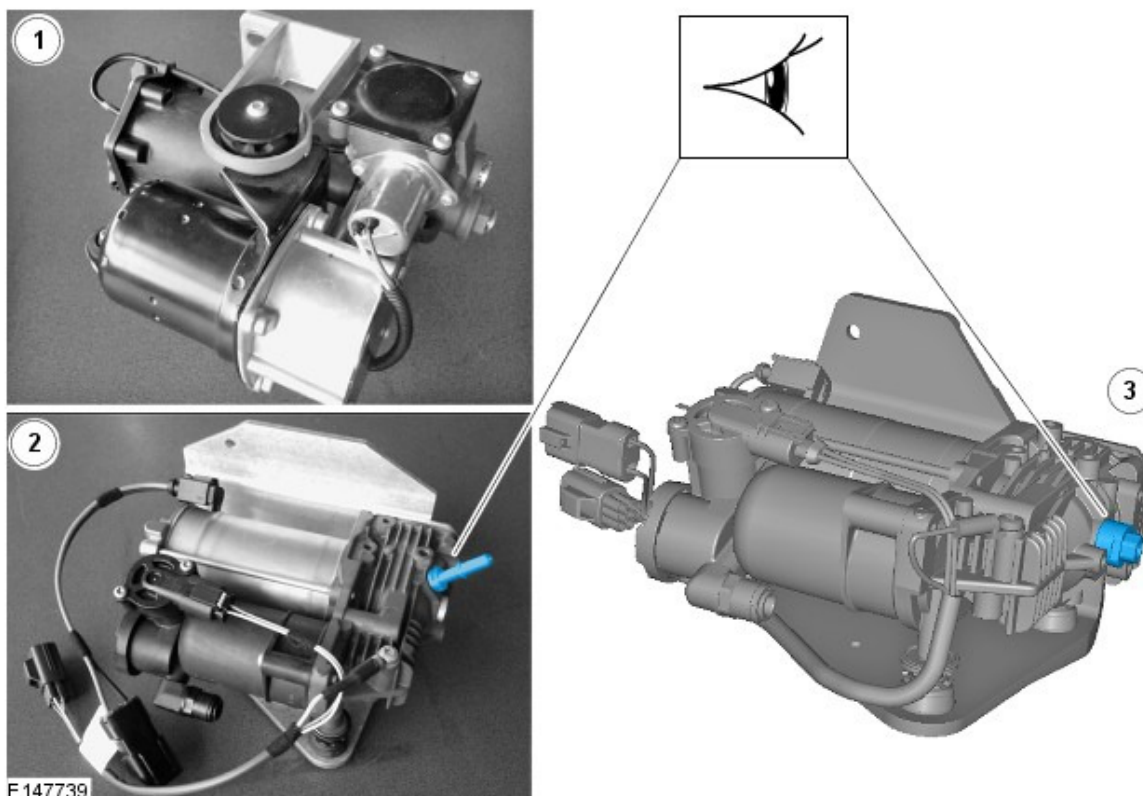

NOTE: Vehicles equipped with Hitachi air suspension compressor.

2. **WARNING:** Steps 2 and 3 must be carried out within 10 minutes of each other, failure to follow this instruction may result in personnel injury.

- ⚠ CAUTION: Make sure the ignition switch is turned off, the park brake is on and the selector lever is in park position.**

Open the front door.

- 3. ⚠ WARNING: Do not work on or under a vehicle supported only by a jack. Always support the vehicle on safety stands.**

Raise and support the vehicle, make sure at least one of the wheels is off the ground.

- 4.** Remove the air suspension compressor lower cover.

- Remove the 3 bolts.
- Release the 5 clips.

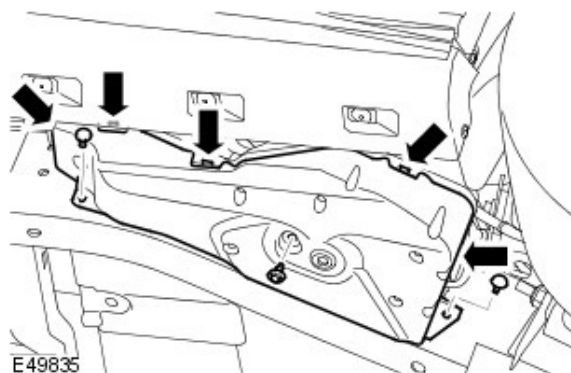

- 5. ⚠ CAUTION: Make sure that the 3 suspension compressor mounting nuts in the chassis rail are not damaged or corroded. If required, replace the nuts.**

- ⚠ CAUTION: Always plug any open connections to prevent contamination.**

- △ NOTE: Access to the top compressor fixing bolt is very restricted. It is advisable to use a 3/8 inch drive socket with a flexible coupling.**

Remove the air suspension compressor.

- Disconnect the 3 air lines.
- Disconnect the 2 electrical connectors.
- Remove the 3 bolts.

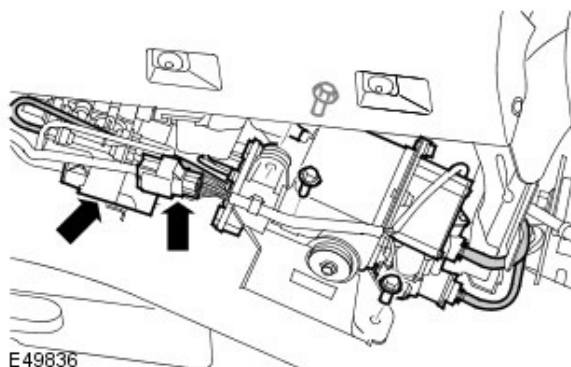

- 6.** Remove and discard the old suspension compressor upper cover.

- 7. ⚠ CAUTION: Make sure that the cover is correctly located behind the bracket as shown. Failure to follow this instruction may cause noise/vibration issues.**

Install the new suspension compressor upper cover.

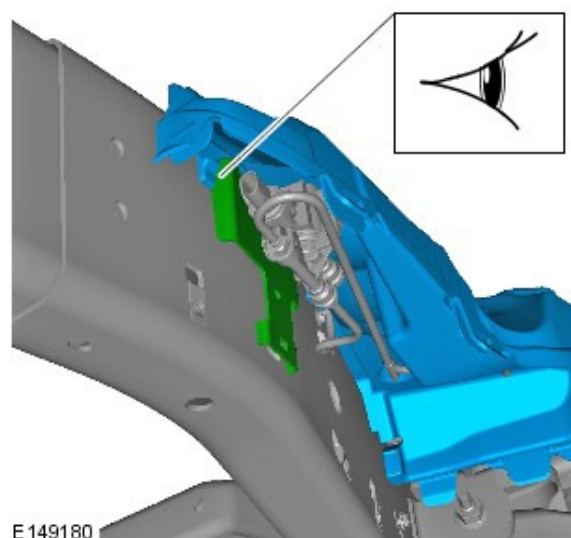

- 8. ⚠ CAUTION: Make sure the new pipe is fitted securely into the new air suspension compressor**

connector, failure to follow this instruction may cause damage to the component.

 **NOTE: Old-design AMK air suspension compressor shown, new-design is similar.**

Install the new exhaust pipe to the new air suspension compressor as shown.

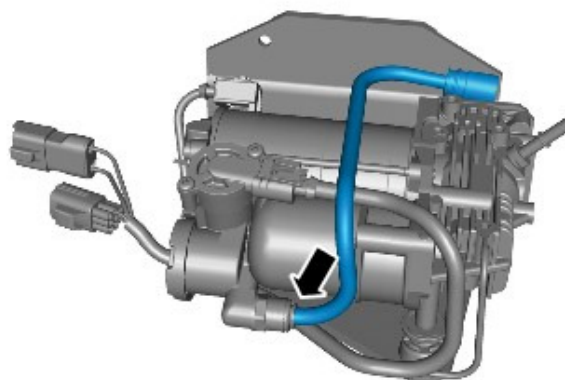

E140275

9.  **NOTE: The pipe to be cut is the smaller diameter pipe.**

Using a suitable pipe cutter tool, cut the air suspension feed pipe in the position indicated.

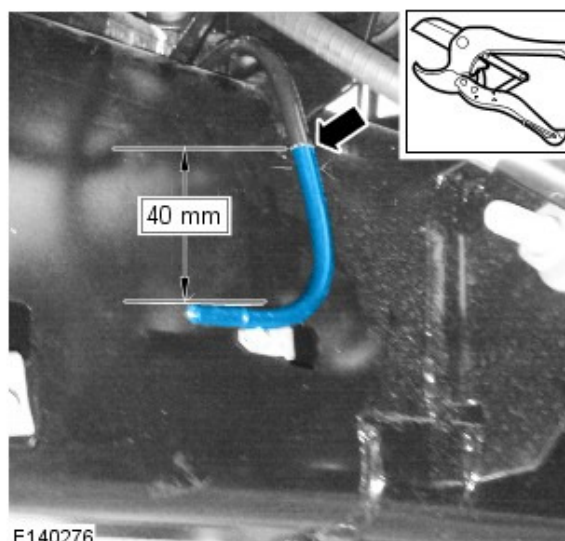

E140276

10.  **CAUTION: Make sure the air line insert is in the correct orientation, failure to follow this instruction may cause damage to the component.**

Install the air line insert until there is no part of the airline insert showing, and it is flush with the end of the air line.

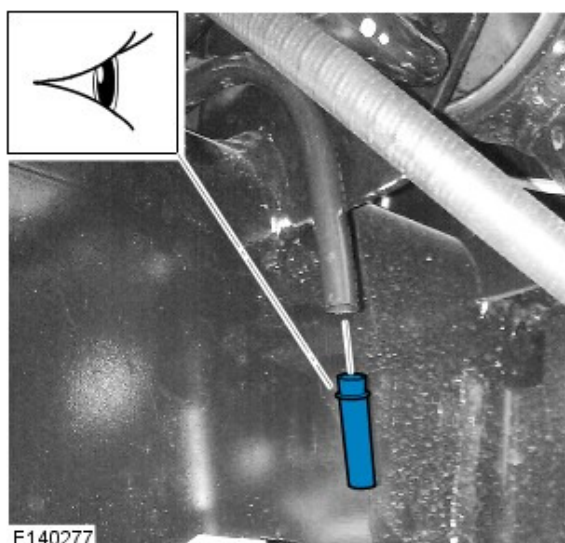

E140277

11. Remove and discard the air line and connector from the valve block.

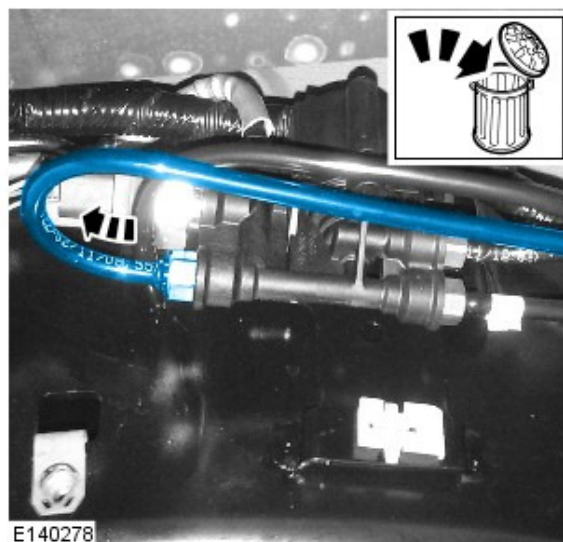

E140278

12.  **CAUTION: Do not remove the blanking plug until after the connector is tightened.**

Install new connector and tighten to 2Nm.

- Remove blanking plug.

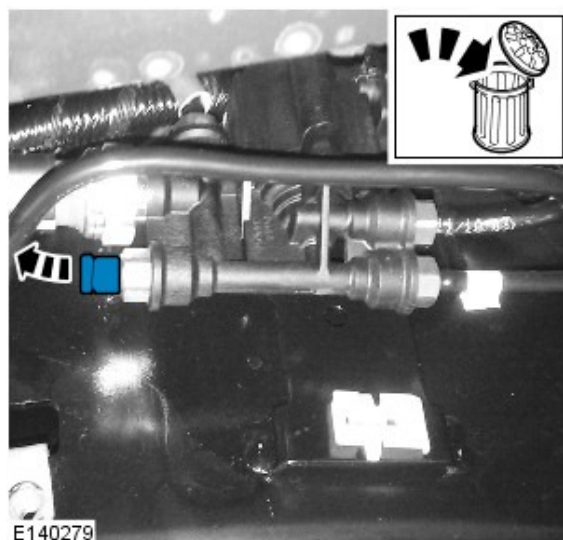

E140279

13.  **CAUTION: Make sure the air line link pipe is correctly fitted. It must be inserted to a depth of 20mm.**

 **CAUTION: Make sure the air lines and wiring are not trapped between the Air Compressor mounting bracket and the chassis, failure to follow this instruction may cause damage to the vehicle.**

Position the new air suspension compressor using the new mounting bolts (do not tighten the bolts fully) and install the new air line link pipe.



E146791

14. Connect the new air line link pipe.

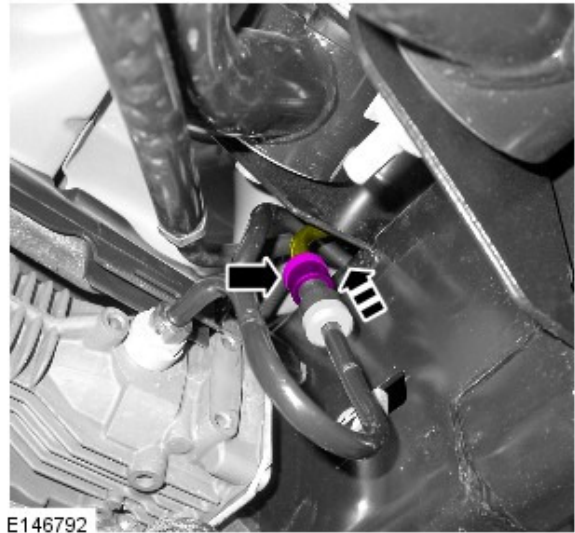

E146792

15. Install the new air line link pipe.

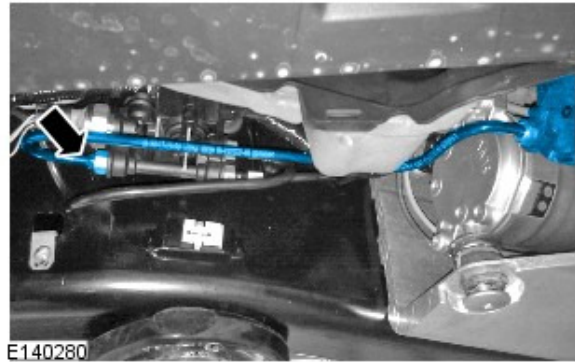

E140280

16.  **CAUTION:** Make sure the air lines and wiring are not trapped between the suspension compressor mounting bracket and the chassis, failure to follow this instruction may cause damage to the vehicle.

 **NOTE:** Make sure that the suspension compressor upper cover is installed correctly.

Secure the suspension compressor and bracket assembly.

- Tighten the 3 bolts to 23 Nm.

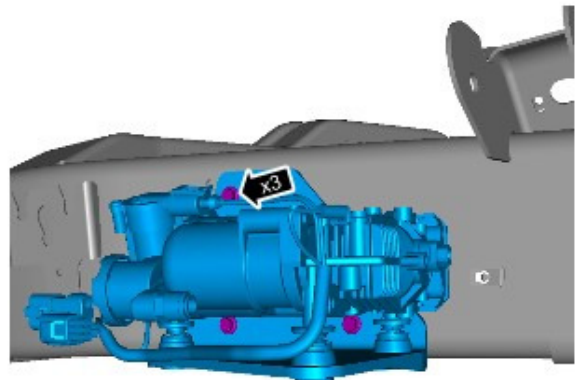

E147657

17.  **NOTE:** Suspension compressor upper cover shown removed for clarity.

Connect the air line.



E 149322

18. Connect the air line and 2 electrical connectors.

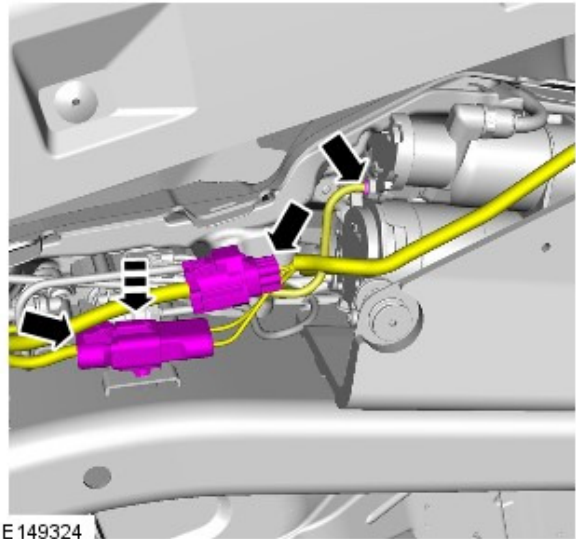

E 149324

19. Install the suspension compressor lower cover.

- Secure the 5 clips.
- Tighten the 3 bolts to 9 Nm.

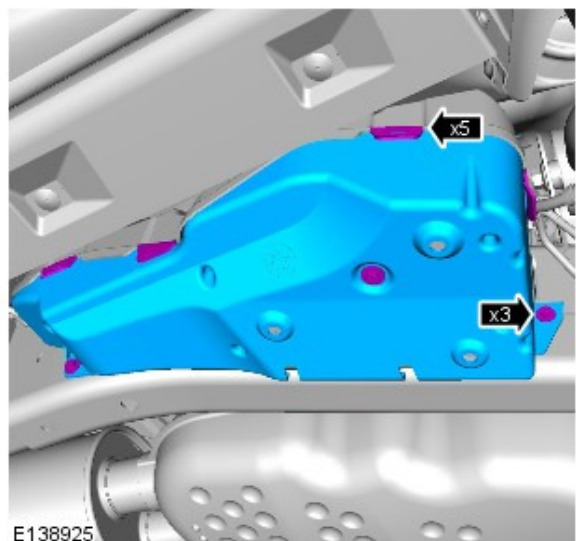

E138925

 **NOTE:** Vehicles equipped with old-design AMK air suspension compressor.

20.  **WARNING: Do not work on or under a vehicle supported only by a jack. Always support the vehicle on safety stands.**

-  **WARNING: Make sure that at least one wheel is off the ground.**

Raise and support the vehicle.

21. Remove the suspension compressor lower cover.

- Remove the 3 bolts.
- Release the 5 clips.

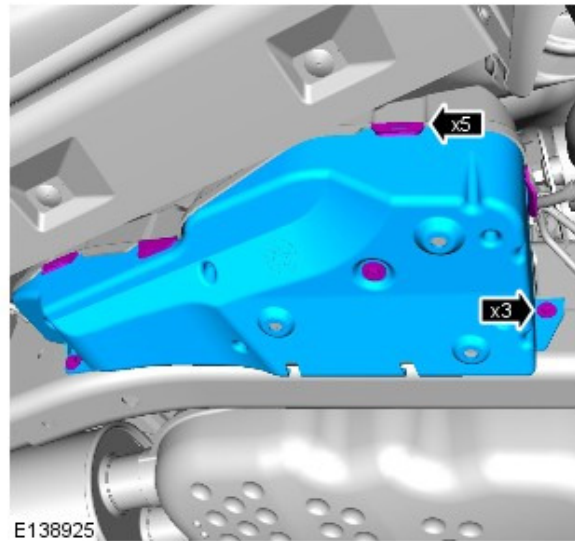

22. Disconnect the 2 air lines.

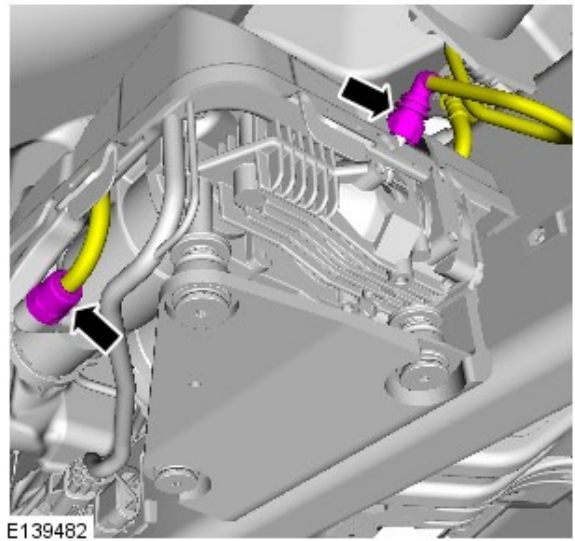

23. If installed, remove and discard the air line link pipe.

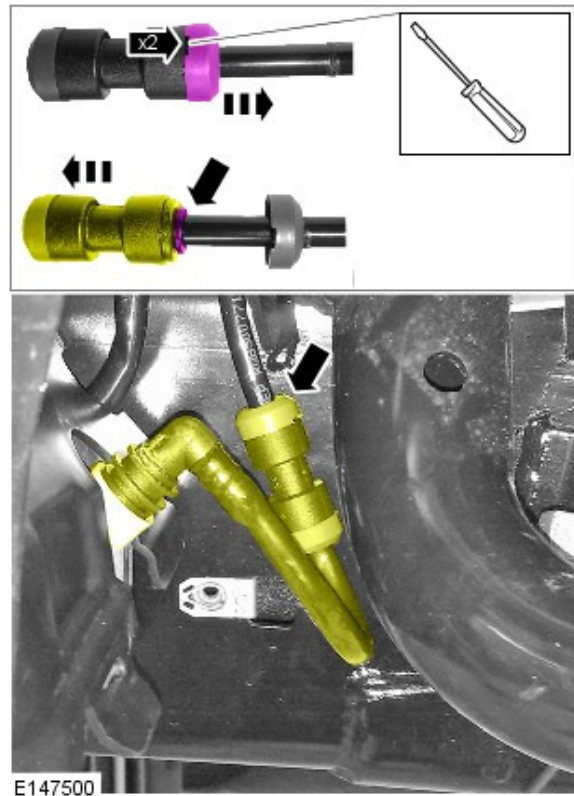

24. Disconnect the air line and 2 electrical connectors.

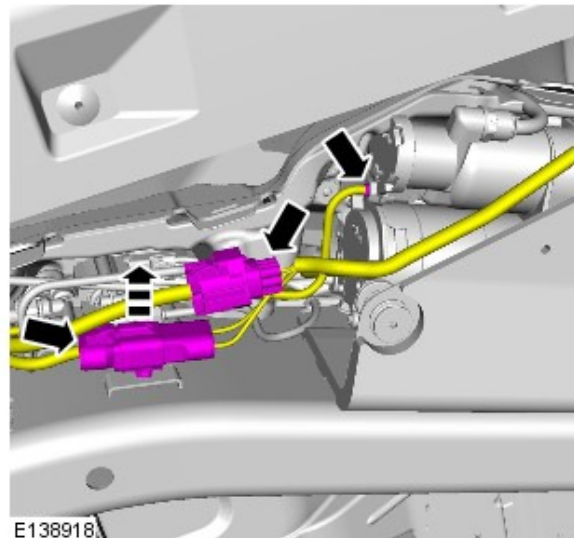

25.  **CAUTION:** Make sure that the 3 suspension compressor mounting nuts in the chassis rail are not damaged or corroded. If required, replace the nuts.

 **NOTE:** New-design AMK air suspension compressor shown, old-design is similar.

Remove the suspension compressor and bracket assembly.

- Remove the 3 bolts.

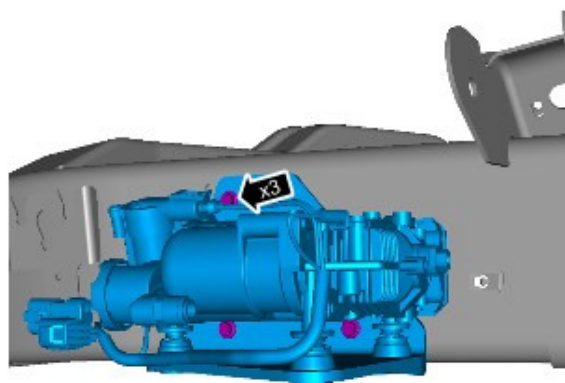

E147657

26. Remove and discard the old suspension compressor upper cover.

27.  **CAUTION:** Make sure that the cover is correctly located behind the bracket as shown. Failure to follow this instruction may cause noise/vibration issues.

Install the new suspension compressor upper cover.

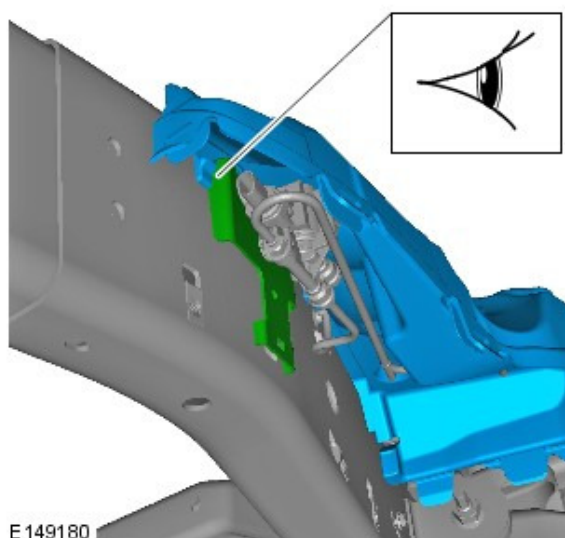

E149180

28.  **CAUTION:** Make sure the air lines and wiring are not trapped between the suspension compressor mounting bracket and the chassis, failure to follow this instruction may cause damage to the vehicle.

 **NOTE:** Make sure that the suspension compressor upper cover is installed correctly.

Install the suspension compressor and bracket assembly.

- Tighten the 3 bolts to 23 Nm.

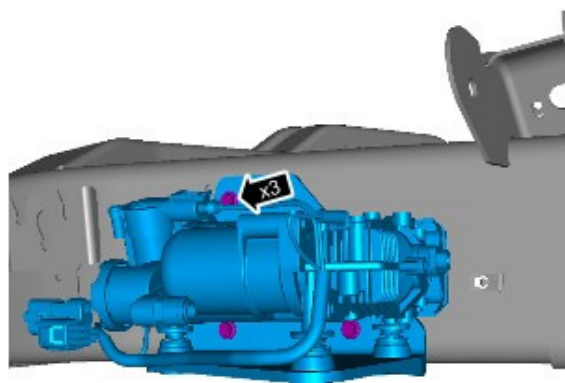

E147657

29.  **NOTE:** Old design AMK compressor shown, new design is similar.

 **NOTE: Component shown removed from vehicle for clarity.**

Connect the air line.

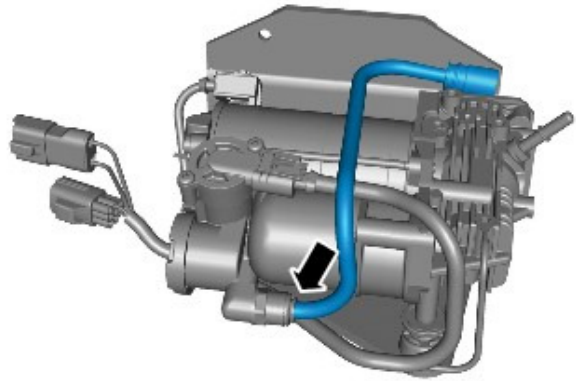

E140275

Vehicles with air link pipe.

30.  **CAUTION: Make sure the air line link pipe is correctly fitted. It must be inserted to a depth of 20mm.**

Install the new air line link pipe.



E146791

31. Connect the new air line link pipe.





E146792

Vehicles without air link pipe.

32. Using a suitable pipe cutter tool, cut the air suspension feed pipe in the position indicated.

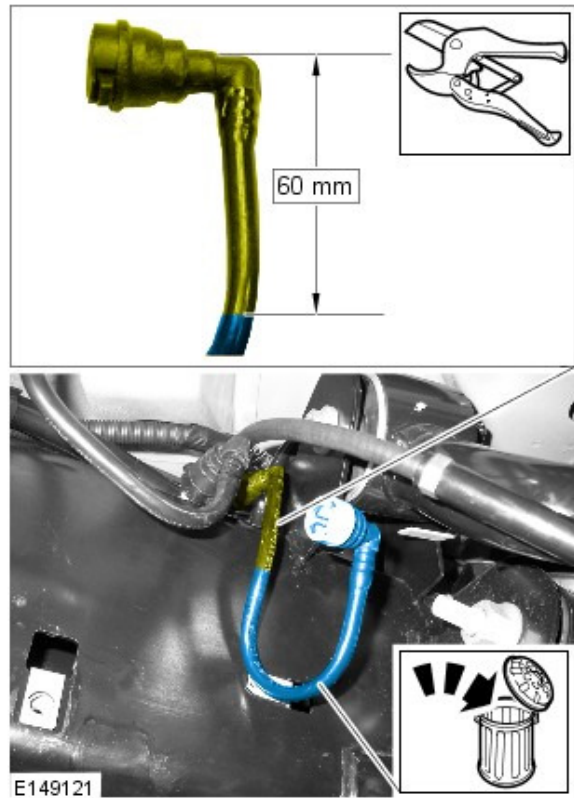
- Discard the lower section of the pipe.



33.  **CAUTION: Make sure the air line insert is in the correct orientation, failure to follow this instruction may cause damage to the component.**

Install the air line insert until there is no part of the airline insert showing, and it is flush with the end of the air line.

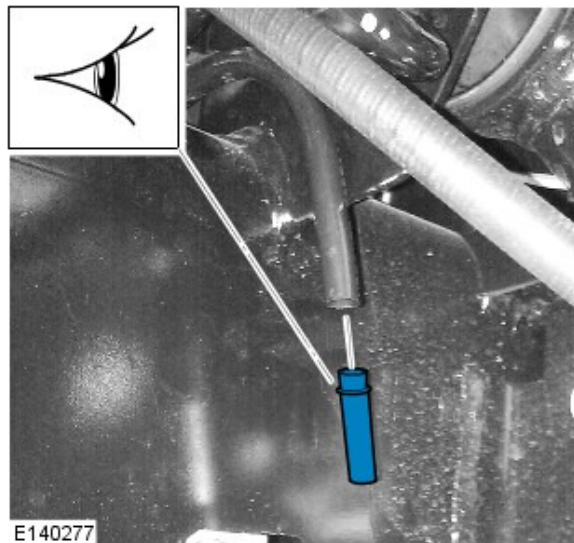

34. Install the new air line link pipe.



All Vehicles.

35. Connect the air line and 2 electrical connectors.

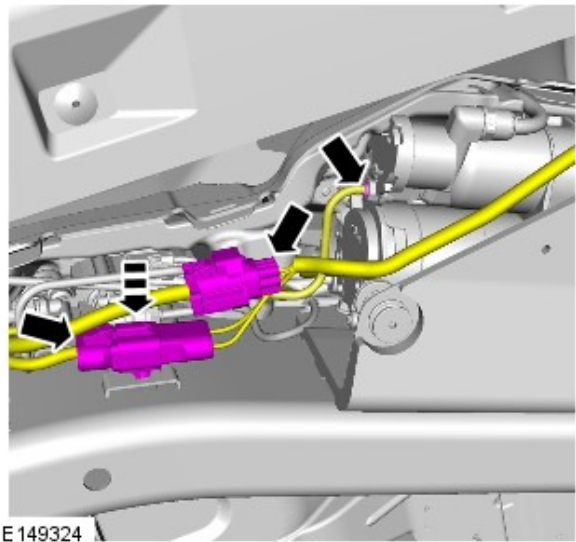

36.  **NOTE: Suspension compressor upper cover shown removed for clarity.**

Connect the air line.



37. Install the suspension compressor lower cover.

- Secure the 5 clips.
- Tighten the 3 bolts to 9 Nm.

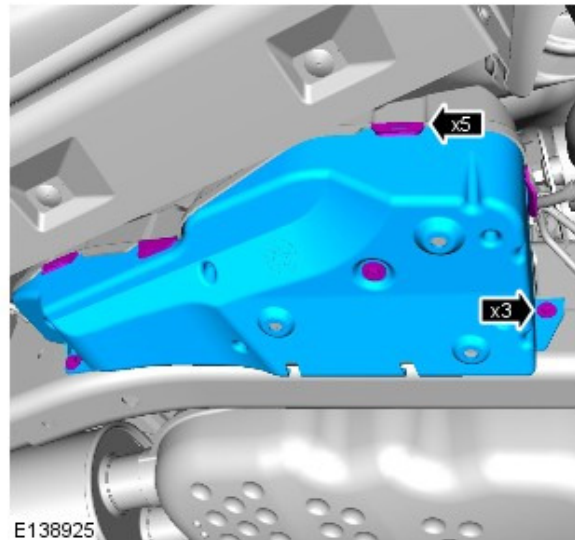

 **NOTE: All Vehicles.**

38.  **NOTE: Location of air suspension relay to be replaced.**

Replace the compressor relay.

1. The relay is located in the fuse box in the engine bay.



39.  **CAUTION: SDD must be loaded with DVD131.07 calibration file 118 loaded or later.**

Connect a Land Rover approved battery conditioner/power supply to the vehicle.

40. Connect SDD to the vehicle and begin a new diagnostic session, by reading the VIN for the current vehicle and initiating the data collect sequence.
41. Select Service Functions session type.
42. Run Air suspension - Air suspension compressor replacement.
43. When all tasks are complete, exit the current session by selecting the Session tab and then selecting the Close Session option.
44. Disconnect SDD and the Land Rover approved battery conditioner/power supply.