

Timing Belt (12.65.18)

Special Service Tools



Check Pin - Camshaft Pulleys
303-1132



Timing Pin - Camshaft Pulleys
303-1126



Timing Pin - Automatic Transmission
303-1117



Timing Pin - Manual Transmission
303-1116

Removal

All vehicles

- 1 . Disconnect the battery ground cable.
For additional information, refer to : Battery, Mounting and Cables, 414-01.
- 2 . Remove the timing belt cover.
For additional information, refer to : Engine-2.7L, 303-01C.

3 .



WARNING : Do not work on or under a vehicle supported only by a jack. Always support the vehicle on safety stands.

Raise and support the vehicle.

- 4 . Remove the starter motor.
For additional information, refer to : Starting System-2.7L, 303-06C.
- 5 . Remove the crankshaft timing alignment grommet from the engine block.
- 6 . Rotate the crankshaft clockwise to align the crankshaft alignment hole in the flywheel or flexplate with the block aperture.
- 7 . Check the camshaft pulley alignment holes are correctly aligned. If the alignment holes are not aligned, rotate the crankshaft one full turn clockwise.

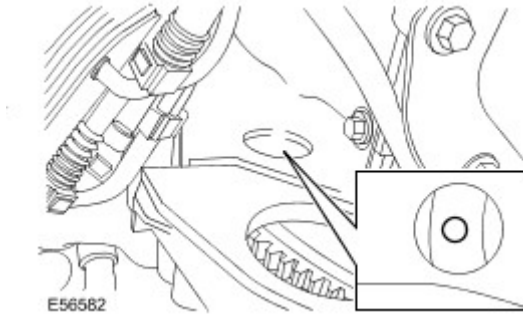

Vehicles with automatic transmission

- 8 . Using the special tool, lock the flexplate.
▶ Install a starter motor bolt to retain the special tool.

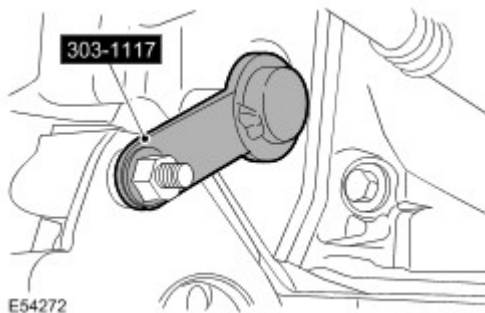

Vehicles with manual transmission

- 9 . Using the special tool, lock the flywheel.
▶ Install a starter motor bolt to retain the special tool.

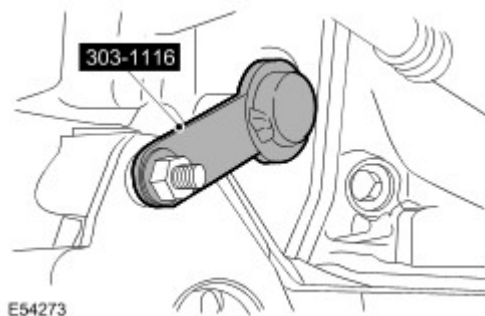

10 . Install the special tools to the exhaust camshaft pulleys.

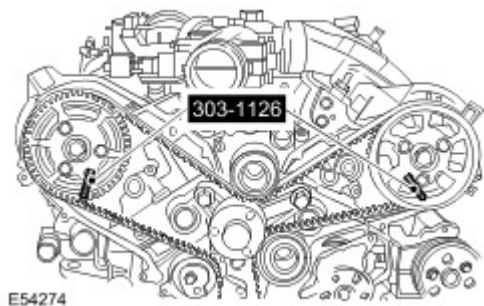

11 .



CAUTION : Do not use the special tools to lock the camshafts. Failure to follow this instruction may result in damage to the engine or the special tools.

Loosen the six exhaust camshaft pulley damper retaining bolts.

▶ Using a suitable tool, counterhold the camshaft pulley center retaining bolts.

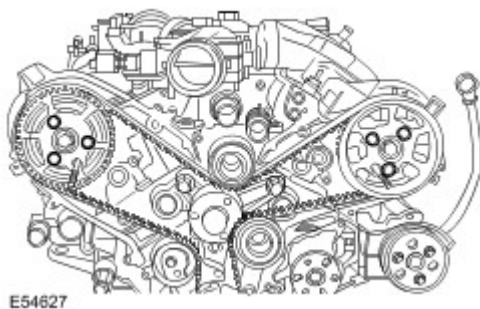

12 . Remove and discard the timing belt tensioner.

▶ Remove and discard the bolt.

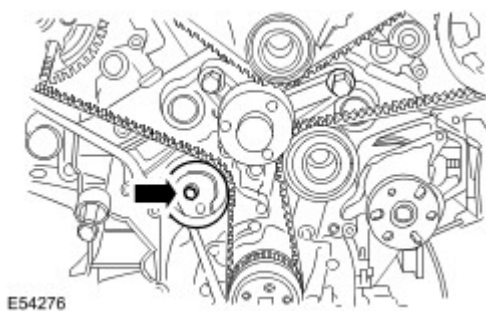

13 . Remove and discard the timing belt.

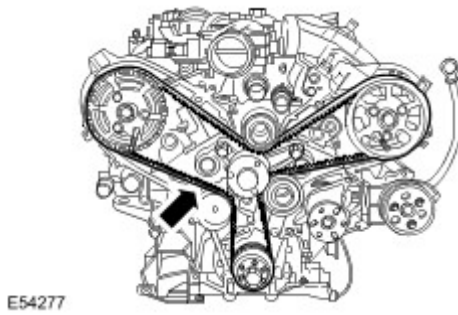

Installation

All vehicles

- 1 . Rotate both camshaft pulleys clockwise.



- 2 . Install a new timing belt tensioner.

▶ Install a new bolt, but do not fully tighten at this stage.

- 3 .



CAUTION : Make sure the camshaft pulleys remain in the clockwise position.

Install the new timing belt.

- ▶ Starting at the crankshaft pulley, install the timing belt in a counter-clockwise direction, in the sequence shown.
- ▶ Stage one: Attach the timing belt to the crankshaft pulley.
- ▶ Stage two: Attach the timing belt to the idler pulley.
- ▶ Stage three: Attach the timing belt to the left-hand camshaft pulley.
- ▶ Stage four: Attach the timing belt to the idler pulley.
- ▶ Stage five: Attach the timing belt to the RH camshaft pulley.
- ▶ Stage six: Attach the timing belt to the timing belt tensioner.

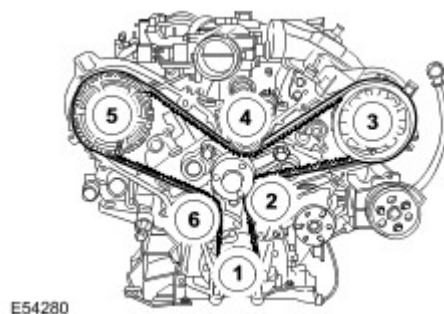

4.



CAUTION : Make sure the timing belt tensioner window is aligned with the groove.

Tension the timing belt.

- ▶ Rotate the tensioner assembly counterclockwise.
- ▶ Tighten to 24 Nm (18 lb.ft).

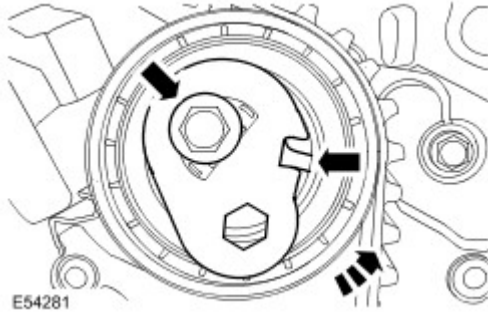

5.



CAUTION : Do not use the special tools to lock the camshafts. Failure to follow this instruction may result in damage to the engine or the special tools.

Using a suitable tool, counterhold the camshaft pulley center retaining bolts.

- ▶ Tighten the six exhaust camshaft pulley damper retaining bolts.
- ▶ Tighten the bolts to 23 Nm (17 lb.ft).

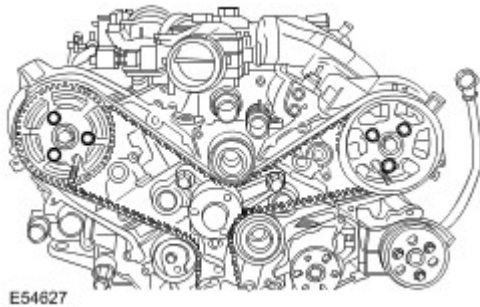

6 . Remove the special tools from the camshaft pulleys.

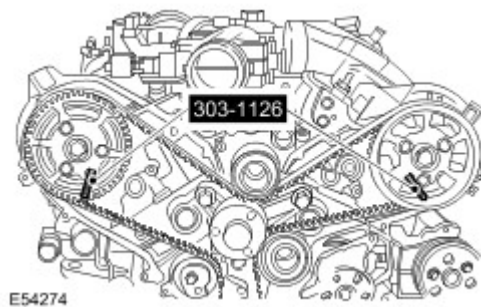

Vehicles with manual transmission

- 7 . Remove the special tool from the flywheel.

Vehicles with automatic transmission

- 8 . Remove the special tool from the flexplate.

All vehicles

- 9 . Rotate the engine two complete turns clockwise.

Vehicles with manual transmission

- 10 . Using the special tool, lock the flywheel.

- ▶ Install a starter motor bolt to retain the special tool.

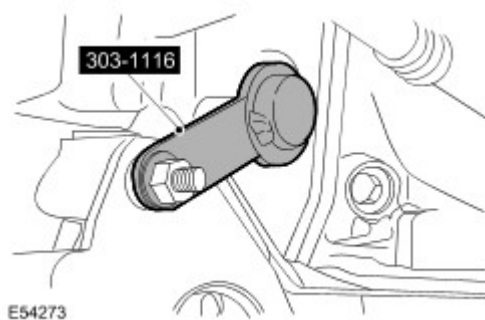

Vehicles with automatic transmission

- 11 . Using the special tool, lock the flexplate.

- ▶ Install a starter motor bolt to retain the special tool.



- 12 . Install the special tools to the exhaust camshaft pulleys.

- ▶ If the special tool does not fit correctly, repeat the timing belt installation procedure.
- ▶ Remove the special tools from the camshaft pulleys.

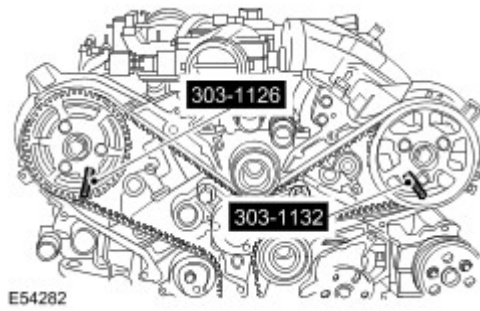

Vehicles with manual transmission

- 13 . Remove the special tool from the flywheel.
▶ Install the grommet.

Vehicles with automatic transmission

- 14 . Remove the special tool from the flexplate.
▶ Install the grommet.

All vehicles

- 15 . Install the starter motor.
For additional information, refer to : Starting System-2.7L, 303-06C.
- 16 . Install the timing belt cover.
For additional information, refer to : Engine-2.7L, 303-01C.
- 17 . Connect the battery ground cable.
For additional information, refer to : Battery, Mounting and Cables, 414-01.