

Cooling System Draining, Filling and Bleeding (26.10.01)

- 1 . Position the vehicle on a lift.
- 2 . Set the heater controls to maximum.
- 3 . Disconnect the battery ground cable.
[Specifications](#)
- 4 . Remove the engine cover.
[Engine Cover - 2.7L Diesel \(12.30.50\)](#)

5 .



WARNING: Since injury such as scalding could be caused by escaping steam or coolant, do not remove the filler cap from the coolant expansion tank while the system is hot.

Remove the coolant expansion tank cap.

- 6 . Remove the radiator access panel.
 - Remove the 4 bolts.

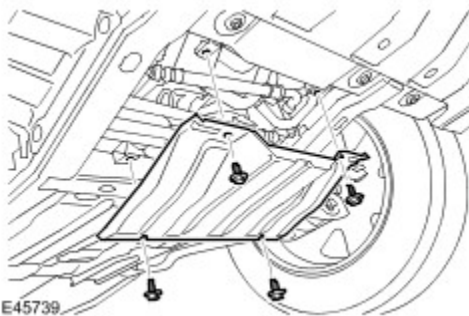

- 7 . Position a container to collect the fluid.

8 .



CAUTION: Engine coolant will damage the paint finished surfaces. If spilt, immediately remove the coolant and clean the area with water.

Release the clip and disconnect the radiator lower hose, allow the coolant to drain.

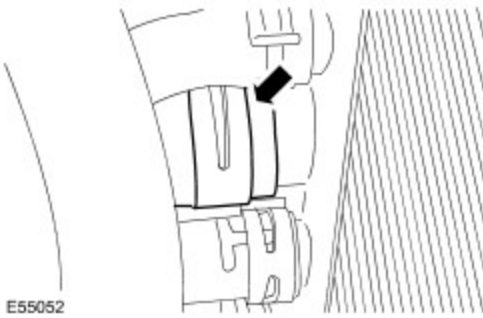

- 9 . Remove the container.
- 10 . Remove the spare wheel and tire.
 - Remove the tool kit.
 - Access the winch.
- 11 . Position a container to collect the fluid.
- 12 . Disconnect the rear heater coolant hoses.
 - Release the 2 clips.
 - Allow the coolant to drain.

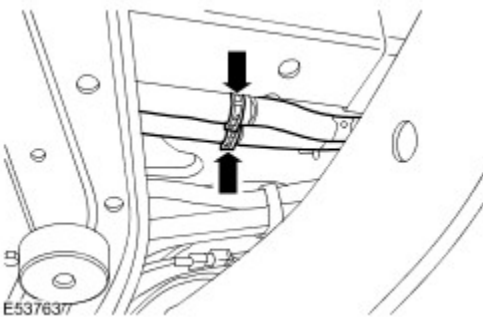

- 13 . Remove the container.
- 14 . Connect the rear heater coolant hoses.
 - Secure the two clips.
- 15 . Install the spare wheel and tire.
 - Stow the tool kit.
- 16 . Connect and secure the radiator lower hose.
 - Secure with the clip.
- 17 . Connect the battery ground cable.

[Specifications](#)

18 . Connect exhaust extraction hoses to the tail pipes.

19 . Loosen the coolant expansion tank bleed screw.



20 . Loosen the cylinder head bleed hose bleed screw.

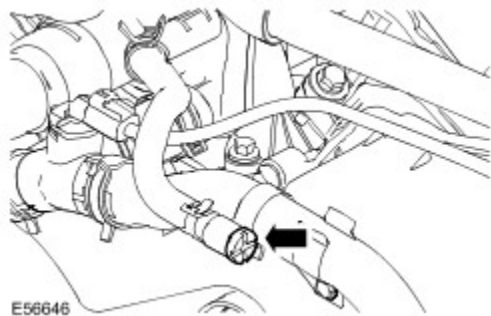

21 . Refill the cooling system.

22 . Tighten the bleed screws to 14 Nm (10 lb.ft).

23 . Fill the cooling system, keeping coolant to the upper level mark of the expansion tank, until a steady stream of coolant is seen returning to the tank.

24 . **NOTE :**

When the coolant bleed is complete and prior to installing the expansion tank cap, top up the expansion tank to 30mm above the maximum level.

Install the coolant expansion tank cap.

25 .



WARNING: Release the cooling system pressure by slowly turning the expansion tank cap a quarter of a turn. Cover the expansion tank cap with a thick cloth to prevent the possibility of scalding. Failure to follow this instruction may result in personal injury.

Start and run the engine.

- Hold the engine speed at 3,000 RPM for one minute.
- Return the engine to idle for five minutes.

- Hold the engine speed at 3,000 RPM for one minute.
- Run the engine until the thermostat opens.
- Remove coolant expansion tank cap, allow float to settle and top-up coolant if required. Install cap.

26 . Switch the engine off and allow to cool.

27 . Install the engine cover.

[Engine Cover - 2.7L Diesel \(12.30.50\)](#)

28 . Clean any remaining coolant from the chassis and surrounding area.

29 . Install the radiator access panel.

- Tighten the 4 bolts to 10 Nm (7 lb.ft).

30 . Check and top-up the coolant if required.

