

Intake Air Distribution and Filtering

Intake Air Distribution

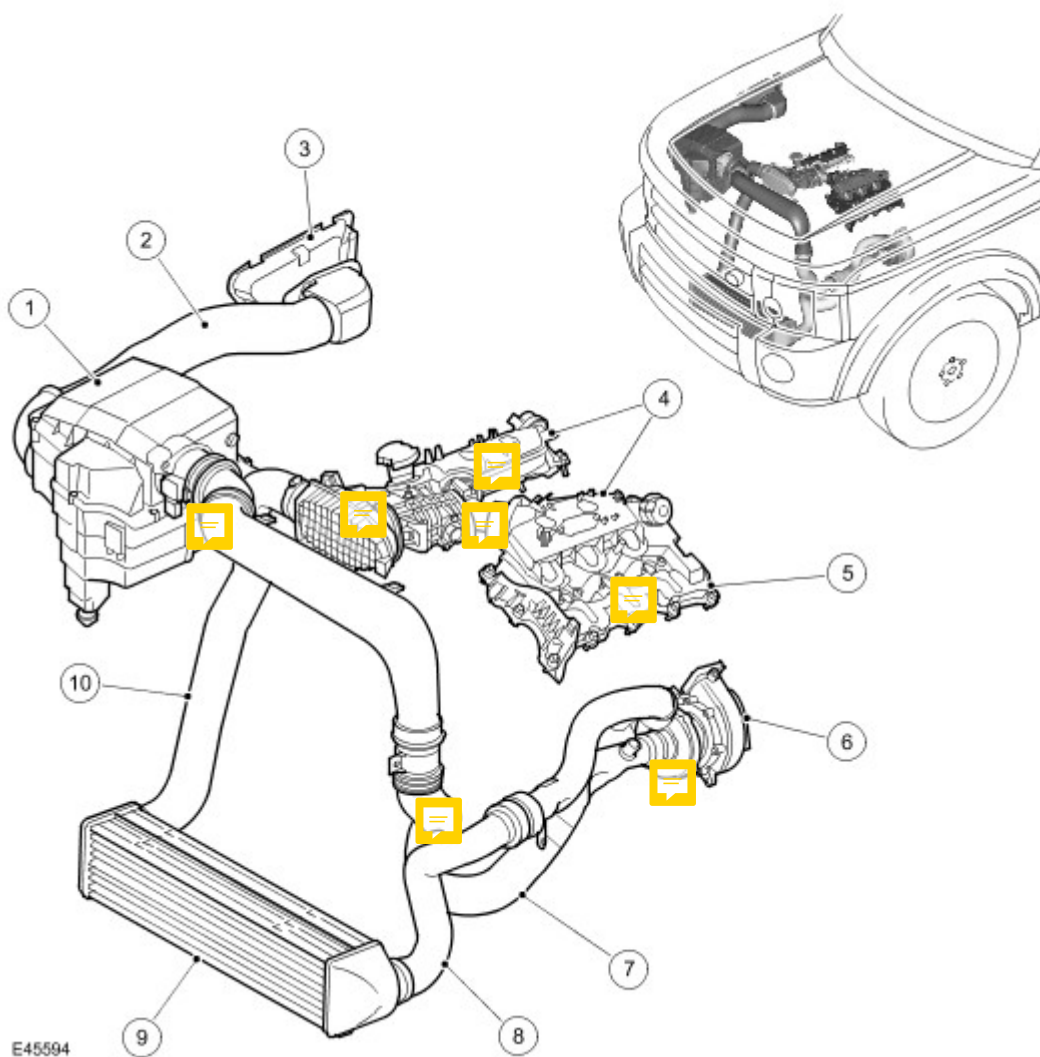

E45594

Item	Part Number	Description
1		Air filter box
2		Air intake duct
3		Air intake manifolds
4		Camshaft cover
5		Turbo charger
6		Air filter to turbo pipe
7		Turbo to charge air cooler pipe
8		Charge air cooler
9		Charge air cooler to intake manifold pipe
10		Filter minder (optional fit for dusty climates)

The 2.7 Liter Diesel air intake and distribution system comprises:

- Wing mounted intake duct
- A filter minder sensor
- Camshaft cover mounted intake manifolds (x2)
- Charge air cooler

- Turbo charger

Air is drawn in from the vehicle exterior via the wing mounted intake duct, along the inside of the wing to the air filter box intake. Once the air has passed through the air filter it is drawn along a duct to the turbo charger. From the turbo charger the air is forced through the charge air cooler up to the electric throttle assembly and then to the inlet manifold assembly.

t

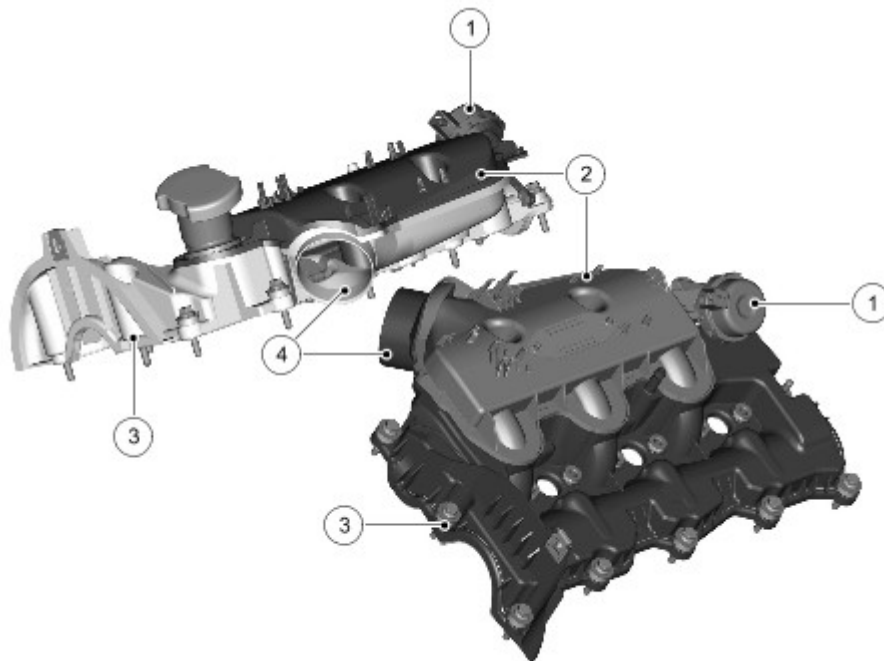

E45595

Item	Part Number	Description
1	-	Port deactivation control valves (not used)
2	-	Air intake manifolds
3	-	Cylinder head covers
4	-	Air intake ducts